

Assembly and Operating Manual

GEDA[®] **LIFT 200 STANDARD** **LIFT 250 COMFORT** **FIXLIFT 250**

Inclined Elevator

for loads

Bearing capacity: Max. 250kg

Year of construction:

Serial number:



Phone + 092-5313388

Fax +

Email: inruksa@hotmail.com

WWW:<http://www.เก้าแสนเพาเวอร์.com>

Inclined lift **GEDA LIFT 200 STANDARD, 250 COMFORT and FIXLIFT 250**

Item No.:	Item	Approx. Weight kg
2030	GEDA® LIFT 200 STANDARD – Bearing capacity up to 200kg , lifting speed 22m/min (= 1-stage), 1 kW/230 V/50 Hz Basic unit consists of: – Electro-winch 230V/50 Hz with 43m cable rope (6mm Ø), 21m limit switch cable, control system with emergency-stop and 5m lead (24 V) – Standard carriage with rope breakage safety device – Head section with deflection sheaf for snap buckle – Foot section 2m	88
2032	GEDA® LIFT 250 COMFORT – Bearing capacity up to 250kg , lifting speed 30m/min (= 1-stage), 1.3 kW/230 V/50 Hz Basic unit as Item No. 2030 – Pluggable control and limit switch	88
2034	GEDA® FIXLIFT 250 – Bearing capacity up to 250kg , 2 lifting speeds 19/38m/min (= 2-stage), 0.6/ 1.2 kW/230 V/50 Hz Basic unit as Item No. 2030 – Pluggable control and limit switch	88
	Extensions to basic unit	
	Ladder part 150/200 kg	
3378	2m with ring nuts complete	9,5
3379	1m with ring nuts complete	5,8
3384	0.75m with ring nuts complete	4,9
3385	0.5m with ring nuts complete	4
	Ladder part 200/250 kg	
2888	2m with ring nuts complete	11,3
2889	1m with ring nuts complete	6,8
2890	0.75m with ring nuts complete	5,8
2891	0.5m with ring nuts complete	4,8
2907	Bundle of ring nuts (10 pieces) with washers and screws	1,1
5643	Aluminium ladder support extendable to 5.7 m	11
	Load suspension devices	
2893	Universal platform with foldable side guards	31
2862	Front guard for universal platform	3,9
2817	Bucket hoist (attachable to universal platform)	6,5
2895	Vario-platform with foldable side guards (adjustable platform inclination)	38
2253	Large transport platform with vertically and horizontally pluggable boards	55
2830	Platform with stabilizers for plate widths of 0.5 – 1.6 m	40
2860	Brick platform with raisable wire mesh guard, 1 hand truck and 2 palletes	40
2818	Dumping skip with tipping device and adjustable stabilizers (only for standard carriages)	64
	Accessories	
2877	Buckling part is progressively adjustable between 20° and 45°	14
2828	Buckling part progressively adjustable between 20° and 45°, rotatable, with short and long handle	16,5
2822	Undercarriage with gear relief	12
2823	Power distributor	8
2824	Cable drum 33 m, cable 3 x 2.5 mm ² (absolutely necessary wire cross section)	8
2829	Extension tube for aluminium ladder support up to 7.4 m	4
2884	Roof tile distributor	11
2826	Roof support (with progressive height adjustment from 37 - 60 cm)	9,4
2886	Bogie for manually transporting the base unit	11
	Special accessories	
2855	Tilting dump carriage with rope breakage safety device	45
2856	Dumping skip (only for tilting dump carriage)	31
2804	Extension cord 20 m for control system (5-pole)	5
2879	Extension cord 20 m for control system (7-pole)	4,4

Table of Contents:

Chapter	Page
1 PREFACE.....	6
2 DATA	7
3 INTENDED USE AND AREA OF APPLICATION.....	8
4 SAFETY.....	9
4.1 EXPLANATIONS OF SYMBOLS AND NOTES	9
4.1.1 <i>Work safety symbol</i>	9
4.1.2 <i>Attention note</i>	9
4.1.3 <i>Note</i>	9
4.2 GENERAL SAFETY.....	9
4.3 OPERATING SAFETY.....	10
4.3.1 <i>Inspection procedures</i>	11
4.3.2 <i>Safety notes for assembly, operation and transport</i>	11
4.3.3 <i>Safety instructions for maintenance</i>	11
4.4 PROMOTING USE OF OPERATING MANUALS.....	12
4.5 EMPLOYEES MUST BE INFORMED ABOUT THE FOLLOWING:	12
5 TECHNICAL DATA	13
6 DESCRIPTION.....	15
GEDA LIFT 200 STANDARD	15
6.1 COMPONENTS AND OPERATING ELEMENTS	16
6.1.1 <i>GEDA LIFT 200 STANDARD</i>	17
6.1.2 <i>GEDA LIFT 250 COMFORT and FIXLIFT 250</i>	17
6.1.3 <i>Manual control for GEDA-LIFT 200 STANDARD and LIFT 250 COMFORT winch</i>	18
6.1.4 <i>Manual control for GEDA FIXLIFT 250 winch</i>	18
6.1.5 <i>Limit switch above</i>	18
6.1.6 <i>Limit switch below (slack rope switch)</i>	19
6.2 ACCESSORIES	19
6.2.1 <i>Bogie for manually transporting the base unit</i>	19
6.2.2 <i>Undercarriage</i>	20
6.2.3 <i>Roof support</i>	20
6.2.4 <i>Roof tile distributor</i>	21
6.2.5 <i>Power distributor</i>	21
7 REQUIREMENTS FOR THE SITE OF INSTALLATION	21
7.1 SUBSURFACE	21
7.2 ELECTRICAL CONNECTION (ON SITE).....	21
8 TRANSPORT	22
9 INSTALLATION	22
9.1 GENERAL SAFETY NOTES.....	22
9.2 ASSEMBLE AND SET UP LADDER PARTS.....	23
9.2.1 <i>Construction without buckling part</i>	24
9.2.2 <i>Construction with buckling part</i>	24
9.3 USING LADDER SUPPORTS.....	26
9.4 USING ROPE WINCH	29
9.5 ROPE ASSEMBLY.....	30
9.6 ASSEMBLING LOAD PLATFORM.....	31
9.6.1 <i>Universal platform</i>	31
9.6.2 <i>Bucket hoist (on universal platform)</i>	33
9.6.3 <i>Vario-platform</i>	33
9.6.4 <i>Large transport platform</i>	35
9.6.5 <i>Platform</i>	37

Inclined lift GEDA LIFT 200 STANDARD, 250 COMFORT and FIXLIFT 250	
9.6.6	<i>Brick platform</i>38
9.6.7	<i>Dumping skip with tipping device</i>39
9.6.8	<i>Using tilting dump carriage</i>41
9.6.9	<i>Dumping skip for tilting dump carriage</i>42
9.6.10	<i>Platform with tilting dump carriage</i>43
9.6.11	<i>Transfer control system</i>43
10	OPERATION44
10.1	SAFETY NOTES44
10.2	IMPERMISSIBLE MODE OF OPERATION44
10.3	SAFETY INSPECTION45
10.4	OPERATING THE LIFT.....45
10.4.1	<i>Operating the GEDA LIFT 200 STANDARD and GEDA LIFT 250 COMFORT</i>45
10.4.2	<i>Operating the GEDA FIXLIFT 250</i>46
10.5	WORK INTERRUPTION/END OF WORK46
10.6	SHUTTING DOWN IN AN EMERGENCY46
11	DISMANTLING (DISASSEMBLY)46
12	MALFUNCTIONS-CAUSE-REMEDY47
12.1	POSSIBLE FAULTS DURING OPERATION.....47
12.1.1	<i>Electricity failure or motor defect</i>47
12.1.2	<i>Load platform is run too high</i>48
13	MAINTENANCE48
13.1	CHECK BEFORE EACH USE48
13.2	WEEKLY INSPECTION/MAINTENANCE.....48
13.3	MONTHLY INSPECTION/MAINTENANCE48
13.4	QUARTERLY INSPECTION/MAINTENANCE48
13.5	EVERY 3000 OPERATING HOURS49
14	MAINTENANCE49
15	DISPOSING OF LIFT50
16	WARRANTY50
COPY OF THE EC CONFORMITY DECLARATION51	
17	APPENDIX FOR ENTERING REOCCURRING INSPECTIONS52

Abbildungsverzeichnis:

Fig. 1	Type plates	7
Fig. 2	Emergency stop button	10
Fig. 3	Cordoned off danger zone	15
Fig. 4	GEDA-LIFT	16
Fig. 5	LIFT 200 STANDARD winch	17
Fig. 6	LIFT 250 COMFORT winch	17
Fig. 7	FIXLIFT 250 winch	17
Fig. 8	Manual control (1-stage)	18
Fig. 9	Manual control (2-stage)	18
Fig. 10	Limit switch above	18
Fig. 11	Limit switch below	19
Fig. 12	Bogie	19
Fig. 13	Assemble bogie	19
Fig. 14	Undercarriage	20
Fig. 15	Roof support	20

Fig. 16 Roof tile distributor	21
Fig. 17 Power distributor	21
Fig. 18 Insert sliding carriage into foot section	23
Fig. 19 Put together ladder parts	23
Fig. 20 Assemble head piece	24
Fig. 21 Assemble buckling part	24
Fig. 22 Adjusting buckling part	24
Fig. 23 Standard buckling part	25
Fig. 24 Load capacity table for ladder parts 150/200 kg	26
Fig. 25 Load capacity table for ladder parts 200/250 kg	26
Fig. 26 Scale for the angle of inclination	27
Fig. 27 Aluminium ladder supports	27
Fig. 28 Aluminium ladder supports	27
Fig. 29 Tension lever	28
Fig. 30 Adjustment angle of the ladder supports	28
Fig. 31 Using rope winch	29
Fig. 32 Plug panel on the winch	29
Fig. 33 Assembly upper limit switch	29
Fig. 34 Unwind rope	30
Fig. 35 Feed rope over head section	30
Fig. 36 PVC notice on head piece	30
Fig. 37 Rope guide on buckling part	30
Fig. 38 Hang rope on sliding carriage	31
Fig. 39 Spring latch on sliding carriage	31
Fig. 40 Putting together the universal platform	31
Fig. 41 Front guard for universal platform	32
Fig. 42 Assemble universal platform	32
Fig. 43 Universal platform	32
Fig. 44 Bucket hoist	33
Fig. 45 Assembling vario-platform board	33
Fig. 46 Vario-platform telescopic support	34
Fig. 47 Vario-platform	34
Fig. 48 Unfolding board and side guards	34
Fig. 49 Assembling boards to the transport platform	35
Fig. 50 Assembling large transport platform	35
Fig. 51 Transport platform	35
Fig. 52 Secure telescopic supports	36
Fig. 53 Adjusting boards	36
Fig. 54 Platform	37
Fig. 55 Stabilizers for ladder track	37
Fig. 56 Brick platform	38
Fig. 57 Hand truck for brick platform	38
Fig. 58 Dumping skip with tipping device	39
Fig. 59 Assembling dumping skip	39
Fig. 60 Tipping device	40
Fig. 61 Rope assembly on tipping device	40
Fig. 62 Emptying dumping skip	41
Fig. 63 Tilting dump carriage	41
Fig. 64 Start-up plate on head section	41
Fig. 65 PVC notice for rope assembly	42
Fig. 66 PVC notice for limit switch	42
Fig. 67 Dumping skip on tilting dump carriage	42
Fig. 68 Platform with tilting dump carriage	43
Fig. 69 Transfer control system	43
Fig. 70 Transfer switch	43
Fig. 71 One-stage manual control	45
Fig. 72 Two-stage manual controls	46
Fig. 73 Releasing the brake	47

1 Preface

Who should read this assembly and operating manual?

- Assembly and operation personnel working on the machine
- Maintenance personnel for the machine (cleaning/servicing)

What does this assembly and operating manual contain?

In this assembly and operating manual you will find instructions regarding

- Intended use
- Residual risks
- Safety
- Installation
- Operation
- Trouble shooting
- Customer service

This assembly and operating manual communicates important information that is a prerequisite for working safely and economically with the machine. The assumption is made that the machine is equipped with all possible options.

What you should do straightaway!

Read this assembly and operating manual carefully before assembly and commissioning, and observe all notes especially the safety instructions.

What does this assembly and operating manual not contain?

This assembly and operating manual is not a repair manual!

You will not find documents about repair work in this assembly and operating manual.

What you should consider when re-selling the machine?

If you sell the machine, pass on these assembly and operating instructions with the annual inspection entries and spare parts list to the purchaser.

2 Data

These operating instructions apply for the following types:

GEDA LIFT 200 STANDARD, GEDA LIFT 250 COMFORT, GEDA-FIXLIFT 250

GEDA [®]		28634
Dechentreiter GmbH & Co. KG D-86663 Asbach - Bäumenheim		CE
GEDA LIFT 200 STANDARD		
Max. Tragfähigkeit 200 kg		
Baujahr	Fabr.Nr.	
Drehzahl 1350 1/min	Zugkraft Winde max. 250 kg	
Hubgeschwindigkeit max. 22 m/min	IP 44	60 % ED
Seillänge max. 63 m, Rundlitzenseil Ø 6 mm 6x19 Standard, verzinkt, Kreuzschlag rechtsgängig Mindest-/Rechnerische Bruchkraft 19/22 kN		
P = 1,0 kW	230V 50Hz 6,4A	C _B = 60µF

GEDA-LIFT 200 STANDARD

GEDA [®]		28633
Dechentreiter GmbH & Co. KG D-86663 Asbach - Bäumenheim		CE
GEDA LIFT 250 COMFORT		
Max. Tragfähigkeit 250 kg		
Baujahr	Fabr.Nr.	
Drehzahl 2780 1/min	Zugkraft Winde max. 300 kg	
Hubgeschwindigkeit max. 30 m/min	IP 44	60 % ED
Seillänge max. 83 m, Rundlitzenseil Ø 6 mm 6x19 Standard, verzinkt, Kreuzschlag rechtsgängig Mindest-/Rechnerische Bruchkraft 19/22 kN		
P = 1,3 kW	230V 50Hz 8,6A	C _A = 80µF C _B = 40µF

GEDA-LIFT 250 COMFORT

GEDA [®]		28635
Dechentreiter GmbH & Co. KG D-86663 Asbach - Bäumenheim		CE
GEDA FIXLIFT 250		
Max. Tragfähigkeit 250 kg		
Baujahr	Fabr.Nr.	
Drehzahl 1300/2700 1/min	Zugkraft Winde max. 300 kg	
Hubgeschwindigkeit max. 19/38 m/min	IP 44	60 % ED
Seillänge max. 83 m, Rundlitzenseil Ø 6 mm 6x19 Standard, verzinkt, Kreuzschlag rechtsgängig Mindest-/Rechnerische Bruchkraft 19/22 kN		
P = 0,6/1,2 kW	230V 50Hz 7/8A	C _A = 80µF C _B = 40µF

Type plate for GEDA FIXLIFT 250

Fig. 1 Type plates

Manufacturer address:



Phone 092-531-3388

Fax

Email: inruksa@hotmail.com

WWW: <http://www.เก้าแสนเพาเวอร์.com>

Country of origin: Made in Germany

3 Intended use and area of application



The machine is an inclined lift that is primarily set up for and determined exclusively for conveying goods and construction material during construction work. Any other use beyond this, such as e.g. transporting persons, is not considered as intended use. The manufacturer/supplier is not liable for any damage resulting from this. The user bears sole responsibility for this risk.

- The GEDA lift may only be used to convey goods and construction material during construction work.

The following belongs to intended use,

- that the assembly, operation and maintenance provisions (assembly and operating manual) provided by the manufacturer are complied with.
- that the foreseeable misconduct of other persons is taken into consideration.
- that national guidelines are observed.

Consequences of non-intended use of the equipment

- Danger for life and limb of the user or a third party.
- Damage to machine and other tangible assets.

Requirements of assembly personnel

The machine may only be assembled, operated and maintained by expert persons (qualified personnel) who can guarantee to handle it appropriately based on their training or knowledge and practical experience, and who are aware of the risks. These persons must be specified for assembly, dismantling and maintenance service by the employer.

Operating personnel

The machine may only be operated by persons who can guarantee to handle it appropriately based on their training or knowledge and practical experience. These persons must

- Be specified by the customer to operate the machine
- Be correspondingly instructed and informed about the risks
- Be acquainted with the assembly and operating manual
- Observe national regulations.

Residual risks



There are residual risks in spite of all the precautions met. Residual risks are potential and not obvious risks, such as e.g.:

- Injuries from uncoordinated work.
- Danger from malfunction in the control system.
- Danger from working on the electrical system.
- Danger from damage to the load suspension device.
- Danger from an inappropriately secured load falling down
- Danger from high wind speeds (> 45km/h).

4 Safety

4.1 Explanations of symbols and notes

4.1.1 Work safety symbol



You will find this symbol next to all safety instructions where there is a risk for life and limb of persons. Observe these instructions and conduct yourself with care!

4.1.2 Attention note

ATTENTION Is found at points where special information and/or rules and prohibitions regarding damage prevention are given to prevent damage to the equipment.

4.1.3 Note

NOTE Is found at points where information is given about using the machine economically or instructions are given regarding the correct working procedure.

4.2 General safety

The machine is built according to the current status of technology and is safe to operate. However, it is due to its work processes that the machine has parts and points that cannot be protected without impairing the function and operating capacity of the unit. For this reason, good personal safety practice is required to protect personnel and equipment. Risks can arise from this equipment if it is used incorrectly by untrained personnel or for non-intended purposes.

- Before transporting, assembling, commissioning, dismantling and maintenance, read and observe exactly the machine assembly and operating manuals and safety notes!

**Read and understand assembly and operating manual first;
during work is too late!**

- Keep the operating manual accessible in close proximity to the machine.
- The generally valid, legal and other binding provisions for accident prevention and environmental protection in the respective country in which the machine is being operated are considered a supplement to the assembly and operating manual (e.g. wearing personal protective gear such as hard hat, safety shoes, etc.).
- Observe attached notices and warning signs.
- Only work while wearing close fitting clothing, safety shoes and hard hat. Do not wear jewellery such as necklaces and rings. There is a risk of injury from getting caught or being pulled in.
- Find a doctor immediately if there are any injuries or accidents.



Consequences of not complying with safety instructions

Non-compliance with safety instructions can result in danger both for persons as well as for the environment and the machine. Non-compliance can lead to a loss of any compensation claims.

Requirements of user personnel

See “Operation“ chapter

4.3 Operating safety

- The machine must be set up and dismantled according to this assembly manual and under supervision by expert personnel determined by the employer.
- Set up the machine in a stable position and secure it or dowel it into the ground with pegs.
- Observe lift bearing capacity: This depends on the length of the lift, the ladder inclination and whether work is carried out with or without a ladder support. See angle of inclination scale as well as load capacity table on the foot section.
- Only use the machine in technically fault-free condition and in a safety and risk conscious manner, while observing the operating manual.
- Immediately remedy faults that could impair safety.
- Immediately shutdown the machine if there are safety-relevant changes to the unit or its operating behaviour, and report the fault to the company management or its representative.
- Do not carry out any changes, mount parts on or make conversions to the machine. This also applies to installing and adjusting safety features, such as e.g. limit switches.
- Do not change, remove, override or bypass safety devices.
- Immediately renew damaged and/or removed notices and warning signs as well as safety labels.
- In situations that present a risk for the operating personnel or the machine, the machine can be shutdown by pressing the EMERGENCY STOP button on the manual control (1).
- Move load platform down and shutdown machine with wind speeds of >45 km/h. (Wind force 6, whistling through wire lines!)

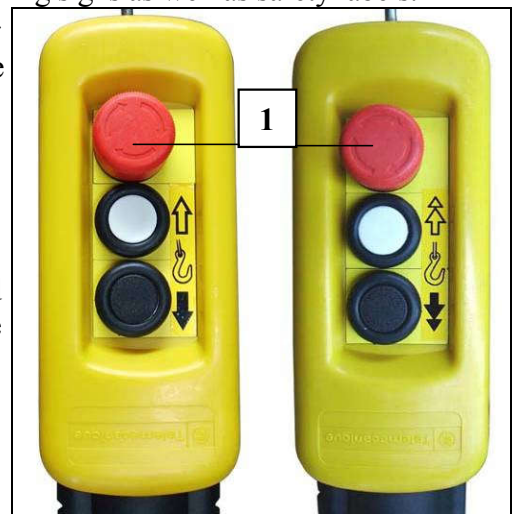

Fig. 2 Emergency stop button

- Do not start the machine if persons could be endangered by the machine, the load suspension device or the load.
- The employer must ensure that the danger zone at the lower loading point is cordoned off, not including the access area to the load suspension device or sling gear.

4.3.1 Inspection procedures

The **GEDA LIFT** is a machine in compliance with the EC machinery directive 2006/42/EC. A copy of the conformity declaration is reproduced in this operating manual.

Tests after each installation → see section 13.1

The following tests have already been carried out at the factory:

- Dynamic test with 1.1x useful load.
- Electrical tests according to EN 60204
- Function tests.

Reoccurring inspections:

- Inspections before commissioning, reoccurring inspections and intermediate inspections are to be carried out according to national guidelines.

NOTE

GEDA recommends that you carry out a recurring inspection on an annual basis. In the case of increased use and strain (e.g. multi-shift operation), carry out inspections at shorter intervals.

- The results of the reoccurring inspection can be recorded in writing in the appendix.

4.3.2 Safety notes for assembly, operation and transport

- Before starting work at the place of utilization, acquaint yourself with the working environment, e.g. obstacles in the work and traffic area, ground load bearing capacity and necessary safeguarding of the construction site from public transport.
- Only load and transport equipment that has been carefully dismantled, packed and tied securely.
- Always secure the machine against unauthorized use (de-energize)! Do not leave any operating parts lying around loose at the end of work or during breaks; remove and secure them under lock and key.
- Position the load carefully on the load plate; material that tends to slip or is higher than the platform or could fall must be secured (think about sudden winds).
- Do not stand or work beneath the load platform!
- Do not place objects under the load platform.
- Load up load suspension device evenly, observe max. bearing capacity.
- Projecting loads are not allowed.
- Vertical use not permitted.
- Check for externally recognizable damage, noises and defects. Immediately report any changes or malfunctions determined to the company management or his/her authorized representative. If necessary, shutdown and secure machine immediately.
- Do not enter the load suspension device!

4.3.3 Safety instructions for maintenance

- Remove mains plug before any maintenance work.
- Only allow servicing and repair work to be carried out by authorized and qualified personnel. In this case, pay attention e.g. also to the special risks present during work on electrical systems.
- Professionally re-attach all dismantled safety devices after maintenance work.
- Independent conversions or changes to the machine impair safety and are not permitted.
- Spare parts must correspond to the technical requirements of the manufacturer. Recommendation: Only use original spare parts from GEDA.

4.4 Promoting use of operating manuals

Operating manuals are rules that the employer puts together for safe operational procedures. This refers to binding instructions that the employer issues within the context of his management rights. The employees are obliged by the accident prevention guidelines to follow these instructions.

The general obligation of the employer to create operating manuals and make them public must be derived from the accident prevention guideline "General Instructions".

According to this guideline, the employer has to fulfil instructions for preventing work-related accidents and must instruct the insured parties in the risks occurring during their work and the measures for averting said risks.

The general obligation of the employer to create operating manuals and make them public must be derived from the accident prevention guideline "General Instructions". These requirements can be fulfilled with the aid of operating manuals.

This operating manual is to supplement national guidelines on accident prevention and environmental protection! e.g.:

EN 60204-1 and EC directives

- 89/655/EEC regarding basic instructions for safety and health protection when using work equipment by the employee during work.

4.5 Employees must be informed about the following:

- The potential risks when working with the load platform and the necessary protective measures and codes of conduct including instructions in the case of danger or about first aid.
- Type and scope of regular inspection for checking that the unit is in a condition safe for work (see Chapter 13).
- Maintenance
- Remediating operational faults.
- Environmental protection
- Safe handling of electrical equipment.
- The user must ensure cleanliness and clarity at the place where the machine is set up by using instructions and checks.
- The responsibilities during setting up and removal (assembly/dismantling), as well as during operating and maintenance, must be clearly regulated by the user and adhered to by all persons so that no unclear competencies occur with regard to safety.
- The user must be obliged to operate the machine only in fault-free condition. He/She is obliged to report immediately to the superior any changes occurring to the equipment that affect safety.
- Observe attached notices and warning signs.
- The user must make sure that no unauthorized persons are located on or near the machine.

5 Technical data

GEDA® LIFT 200 STANDARD

- Motor output	1.0 kW
- Motor current	6.4A
- Duty cycle (DC)	60%
- Protective system	IP 44
- Winch weight (with 43m rope):	56kg
- Max. ladder rail length up to the eaves:	19m
- Hoisting speed:	22m/min
- Max. bearing capacity:	200kg
- Length of ladder part:	0.5m / 0.75m / 1m / 2m
- Dimensions e.g. for 18.3m (lift packaged)	2.2 m x 0.8 m x 1.15 (1.45 m)
- Rope length	43 m, max. 63 m

GEDA® LIFT 250 COMFORT

- Motor output	1.3 kW
- Motor current	8.6A
- Duty cycle (DC)	60%
- Protective system	IP 44
- Winch weight (with 43m rope):	48kg
- Max. ladder rail length up to the eaves:	19m
- Hoisting speed:	30 m/min
- Max. bearing capacity:	250kg
- Length of ladder part:	0.5m / 0.75m / 1m / 2m
- Dimensions e.g. for 18.3m (lift packaged)	2.2 m x 0.8 m x 1.15 (1.45 m)
- Rope length	43 m, 63 m, max. 83 m

GEDA® FIXLIFT 250

- Motor output	0.6/1.2 kW
- Motor current	7 / 8A
- Duty cycle (DC)	60%
- Protective system	IP 44
- Winch weight (with 43m rope):	48kg
- Max. ladder rail length up to the eaves:	19m
- Hoisting speed:	19/38 m/min.
- Max. bearing capacity:	250kg
- Length of ladder part:	0.5m / 0.75m / 1m / 2m
- Dimensions e.g. for 18.3m (lift packaged)	2.2 m x 0.8 m x 1.15 (1.45 m)
- Rope length	43 m, 63 m, max. 83 m

General:

- Winch transmission group	"M2" according to FEM 1001 issue No. 2
- Noise emission levels (the measuring uncertainty constant is 4 dB (A))	$L_{PA} < 78$ dB (A)
- Dynamic pressure according to pr EN 12158-2:	
During assembly	$q = 100$ N/m ² (= 45 km/h)
While operating	$q = 100$ N/m ² (= 45 km/h)
While shutdown	Load suspension device on ground

Basic unit consists of:

- 1 Electro-winch 230V/50Hz with 43m cable rope – 6mm DIN 3060 SE 1770 minimum breaking strength 19.7kN
- Limit switch with 21m lead (pluggable on LIFT 250 COMFORT and FIXLIFT)
- Manual control with 5 m lead (pluggable on LIFT 250 COMFORT and FIXLIFT)
- Standard carriage with rope breakage safety device
- 1 foot section 2m
- Head section

Extensions to Inclined lift

GEDA LIFT 200 STANDARD, GEDA LIFT 250 COMFORT, GEDA-FIXLIFT 250

	With Ladder part 150/200 kg	With Ladder part 200/250 kg
- Ladder part 2m complete with ring nuts	9.5kg	11.3kg
- Ladder part 1m complete with ring nuts	5.8kg	6.8kg
- Ladder part 0.75 m complete with ring nuts	4.9kg	5.8kg
- Ladder part 0.5 m complete with ring nuts	4kg	4.8kg
- Aluminium ladder support 5.4m	11kg	11kg
- Extension 2.0m to aluminium ladder support	4kg	4kg

Load suspension devices

- Universal platform with foldable side guards	31kg
- Front guard for universal platform	3.9kg
- Bucket hoist attachable to universal platform	6.5kg
- Vario-platform with foldable side guards	38kg
- Large transport platform with vertically and horizontally pluggable boards (adjustable platform inclination)	55kg
- Platform with stabilizers adjustable for plate widths of 0.5 – 1.6 m	40kg
- Brick platform with raisable wire mesh guard, 1 hand truck and 2 palettes	40kg
- Dumping skip with tipping device (only for standard carriages)	64kg

Accessories

- Buckling part progressively adjustable between 20° and 45°, rotatable, with short and long handle	16.5kg
- Buckling part is progressively adjustable between 20° and 45°	14kg
- Undercarriage with gear relief	12kg
- Power distributor	8kg
- Cable drum with 33 m, 3 x 2.5 mm ²	8kg
- Extension tube for aluminium ladder support up to 7.4m	4kg
- Bogie for manually transporting the base unit	11kg
- Roof tile distributor	11kg
- Roof support	9.4kg

Special accessories

- Tilting dump carriage with rope breakage safety device	45 kg
- Dumping skip for tilting dump carriage	31kg

6 Description

- All GEDA inclined lifts can be constructed to a rail track length of 19 m up to eaves height.
- Assembly is carried out without tools and directly at the work site.
- The handy, light-weight aluminium rails are interlocked and screwed by hand.
- The lift switches off automatically when it reaches the upper or lower end or the rope becomes slack.
- Different load suspension devices (see Chp. 5) are the same for all three variants.
- If the foot section is extended with reinforced ladder sections, then the maximum load bearing capacity increases to 250kg, as can be see on the bearing capacity data on the foot section (see Fig. 24 and Fig. 25).
- The danger zone, excluding the access point to the load suspension device, must be cordoned off and marked.
- It is operated outside of the danger zone using the manual control.

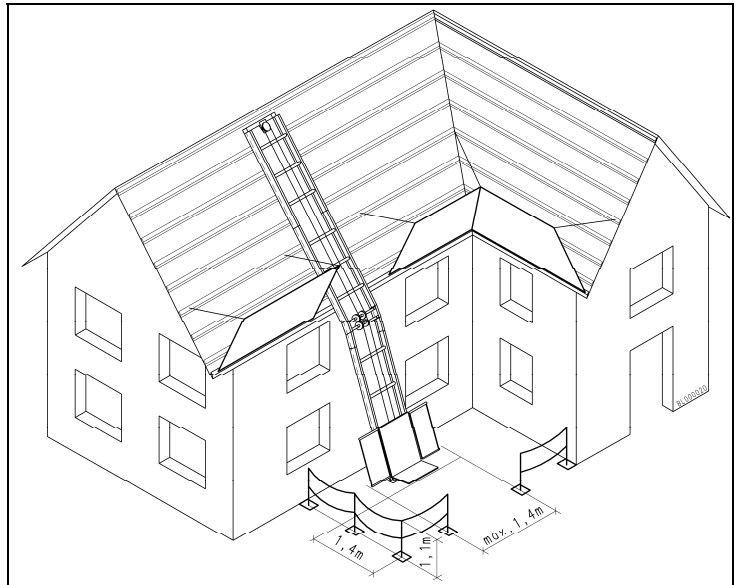

Fig. 3 Cordoned off danger zone

GEDA LIFT 200 STANDARD

- 1 Lifting speed
Hoisting speed of the sliding carriage max. 22m/min.
- The lift is operated with the manual control.
- The up and down direction can be selected using the manual control.

GEDA LIFT 250 COMFORT

- 1 Lifting speeds
Hoisting speed of the sliding carriage max. 30m/min.
- The lift is operated with the pluggable manual control.
- The up and down direction can be selected using the manual control.

GEDA FIXLIFT 250

- 2 Lifting speeds
Starting and stopping with 19m/min.; between starting and stopping, the hoisting speed of the sliding carriage is max. 38m/min.
- The lift is operated with the pluggable manual control.
- The up and down direction can be selected in two speed levels using the manual control.

6.1 Components and operating elements

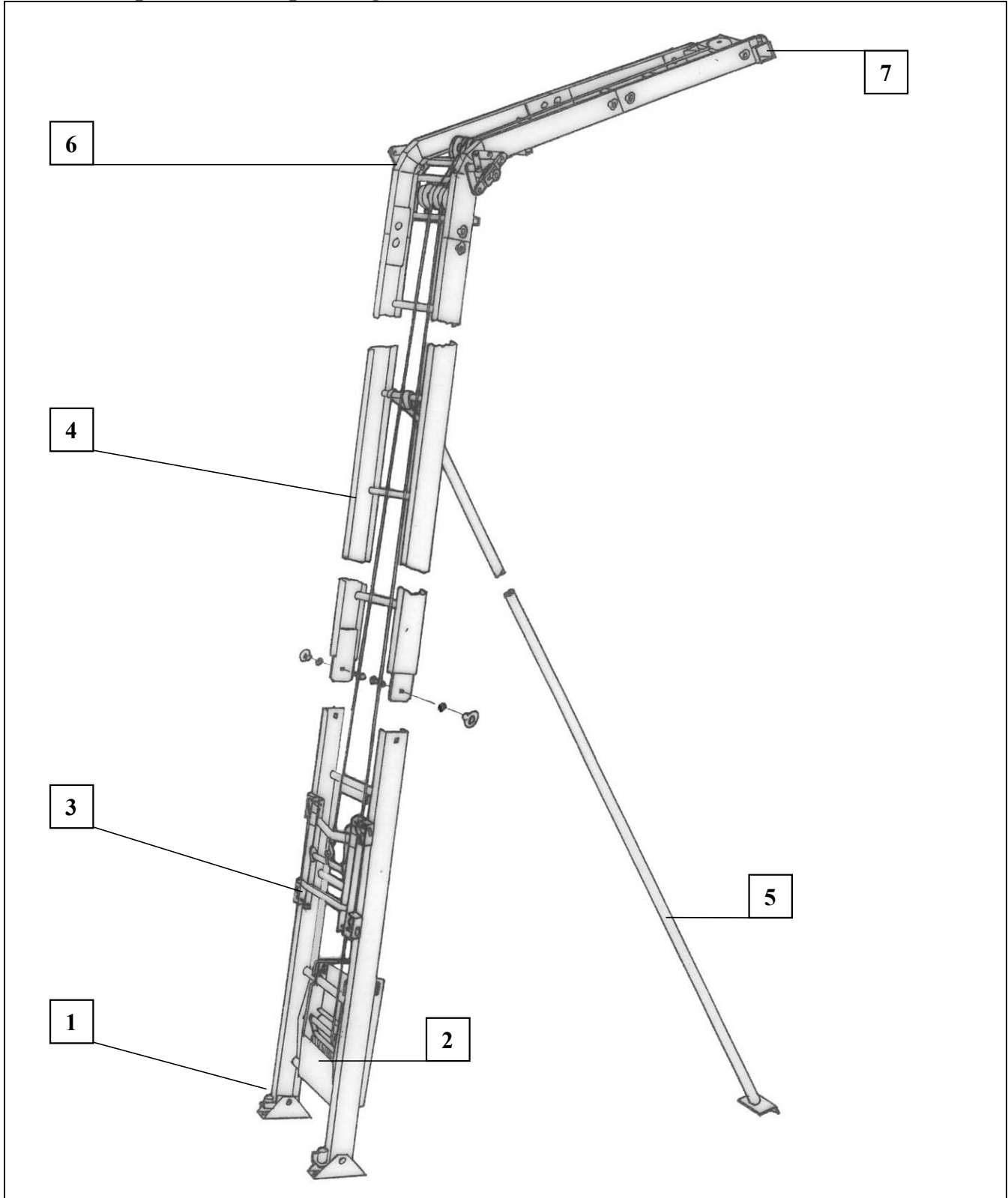

Fig. 4 GEDA-LIFT

1 = Foot ladder part
2 = Winch
3 = Standard carriage
4 = Ladder part

5 = Aluminium ladder support, extendable
6 = Buckling part
7 = Head piece

6.1.1 GEDA LIFT 200 STANDARD

The manual control and the up limit switch are permanently connected to the GEDA-LIFT 200 STANDARD design winch.

- 1 = "GEDA LIFT 200 STANDARD" winch
- 2 = Control cable
- 3 = Mains line with plug
- 4 = Limit switch line

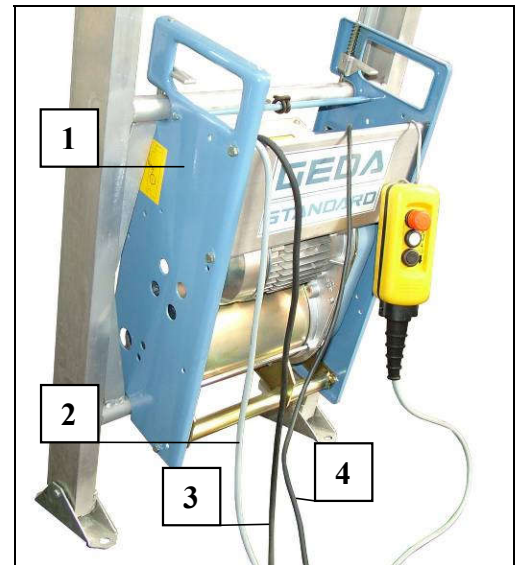

Fig. 5 LIFT 200 STANDARD winch

6.1.2 GEDA LIFT 250 COMFORT and FIXLIFT 250 LIFT 250 COMFORT winch

On the winch for the LIFT 250 COMFORT and FIXLIFT 250 winch designs, the manual control and the up limit switch are connected via plug and socket connections to the winch and can therefore be removed.

- 1 = "GEDA LIFT 250 COMFORT" winch
- 2 = Plug socket 5-pole (grey) for manual control
- 3 = Plug socket 3-pole (grey) for the upper limit switch
- 4 = Mains line with plug

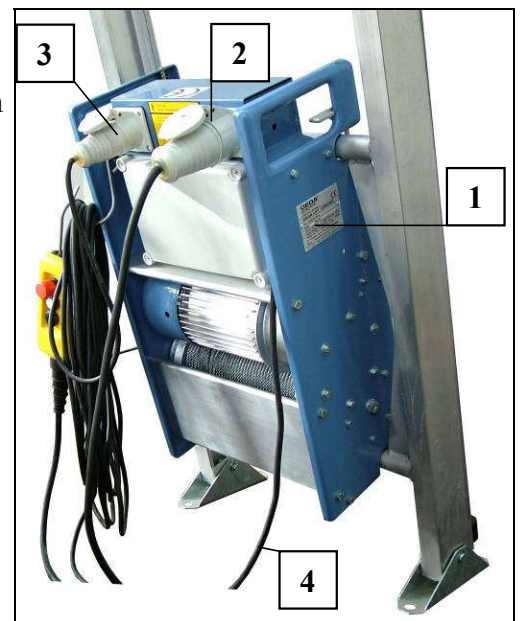

Fig. 6 LIFT 250 COMFORT winch

- 5 = Plug socket 7-pole (blue) for manual control

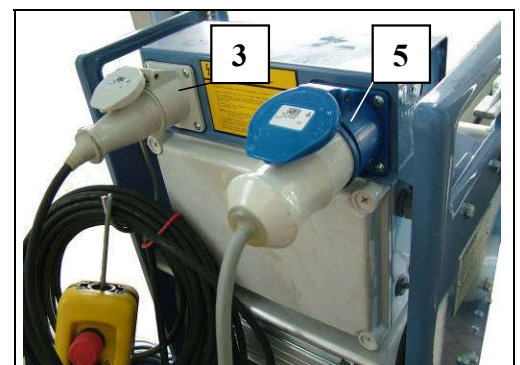

Fig. 7 FIXLIFT 250 winch

6.1.3 Manual control for GEDA-LIFT 200 STANDARD and LIFT 250 COMFORT winch

The manual control switches on the speed level for up and down directions. The manual control on the "LIFT 250 COMFORT" winch is constructed with a plug.

- 1 = EMERGENCY STOP button
- 2 = UP button
- 3 = DOWN button
- 4 = Hanging bracket

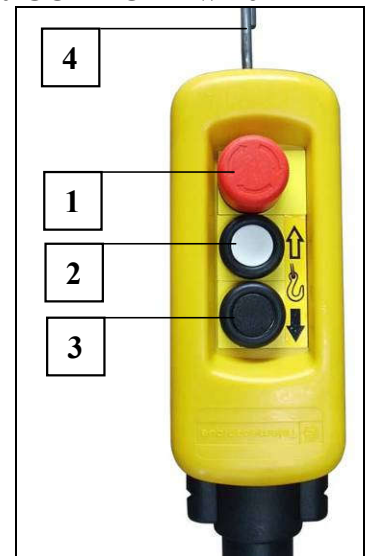

Fig. 8 Manual control (1-stage)

6.1.4 Manual control for GEDA FIXLIFT 250 winch

The manual control for the "FIXLIFT 250" is constructed with a plug.

- 1 = EMERGENCY STOP button
- 2 = UP button
- 3 = DOWN button
- 4 = Hanging bracket

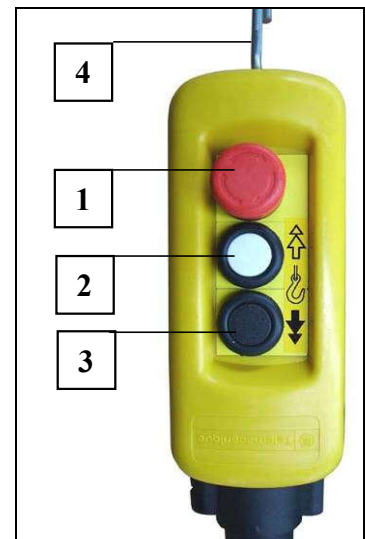

Fig. 9 Manual control (2-stage)

6.1.5 Limit switch above

The limit switch above (1) is the same on all winches. On the "LIFT 200 STANDARD" winch, the limit switch line is securely clamped to the switchbox on the winch.

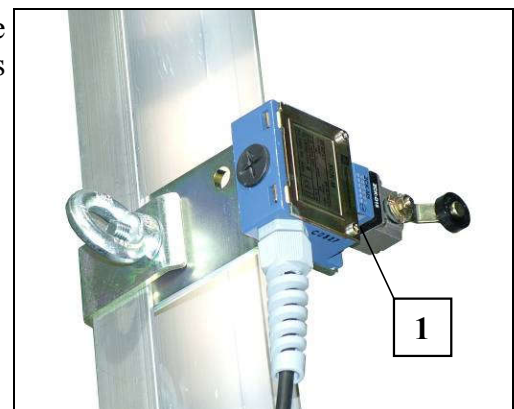

Fig. 10 Limit switch above

6.1.6 Limit switch below (slack rope switch)

The lower limit switch is operated by the slack rope switch.

- The rope is fed by the slack rope switch (1) and is tensioned by the sliding carriage with a load suspension device.
- If the sliding carriage runs to the foot section, then the rope is loose and the slack rope switch (1) stops the downward journey.

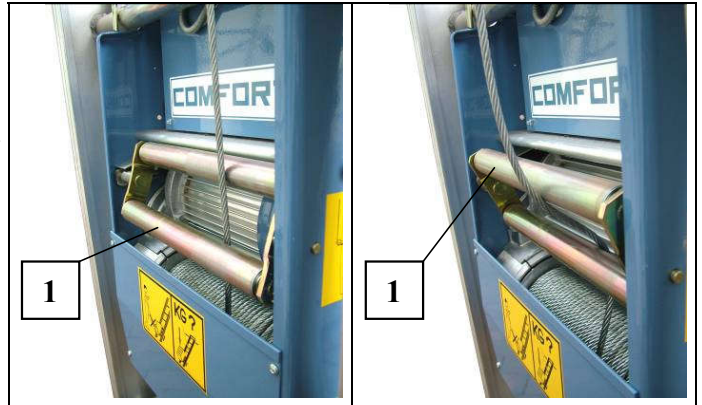

Fig. 11 Limit switch below

6.2 Accessories

6.2.1 Bogie for manually transporting the base unit

- For manually transporting the winch or the disassembled lift unit (foot section with winch and sliding carriage, possibly with universal platform and all elevator parts)
- Secure loose parts with the lashing strap (2) provided.

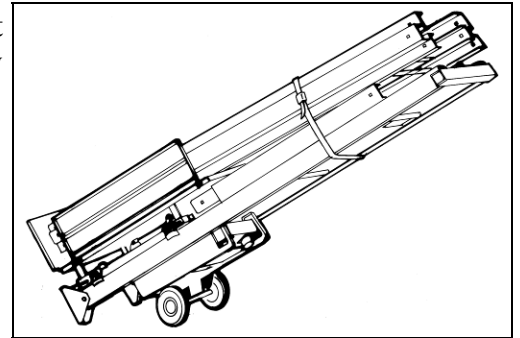

Fig. 12 Bogie

- Place bogie (1) on winch from behind (clamp must lock from below), turn both clamping straps to the outside and securely fasten the bogie by pulling both eye bolts tight.

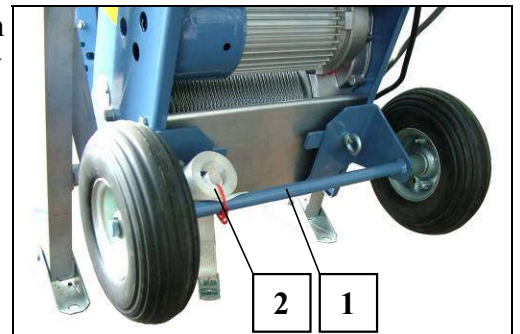

Fig. 13 Assemble bogie

6.2.2 Undercarriage

Undercarriage (with gear relief) for pushing the inclined lift to the side once it is ready for operation. Before setting up the inclined lift on the foot section,

- Dismantle shoes
- Peg out undercarriage with two bolts and secure. - The wheels must point to the front.

NOTE

Run the sliding carriage down before relocating the inclined lift.

- Relieve undercarriage (1) of load during operation; to do this
 - Press down manual lever (2)
 - Lift safety clamp (3)
 - Lift manual lever (2) again.

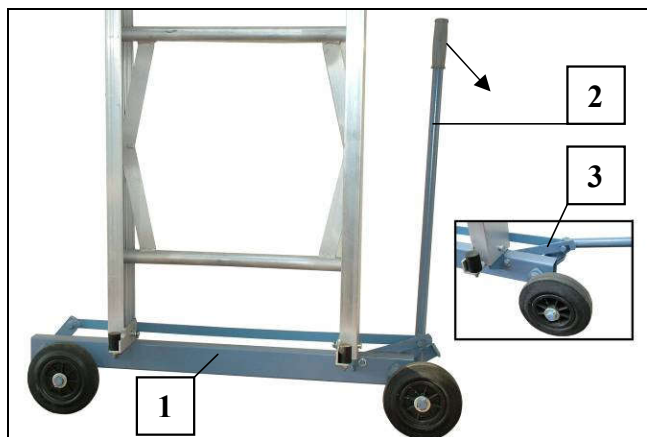

Fig. 14 Undercarriage

6.2.3 Roof support

Roofing is possible under the ladder track with the roof support.

- Insert roof support (1) in a rung (4) of the ladder track lying on the roof and secure with a spring latch (3).
- Adjust the height using both external clamps (2).

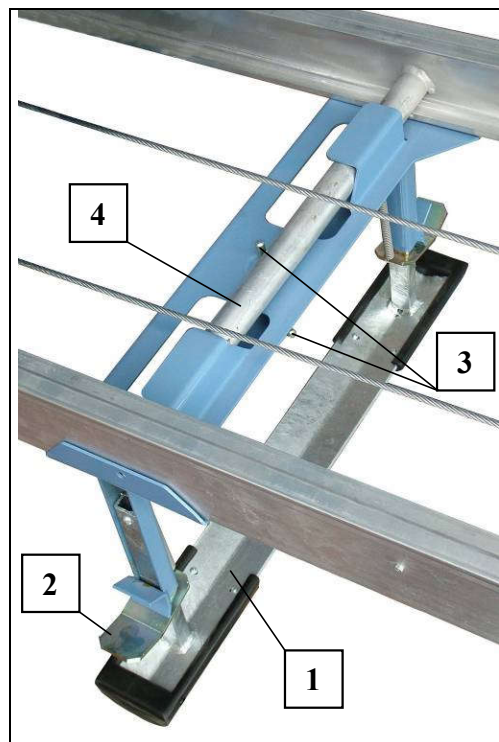

Fig. 15 Roof support

6.2.4 Roof tile distributor

For horizontal distribution of roofing tiles on the roof.

- Place roof tile distributor on the roof battens and push to the side.

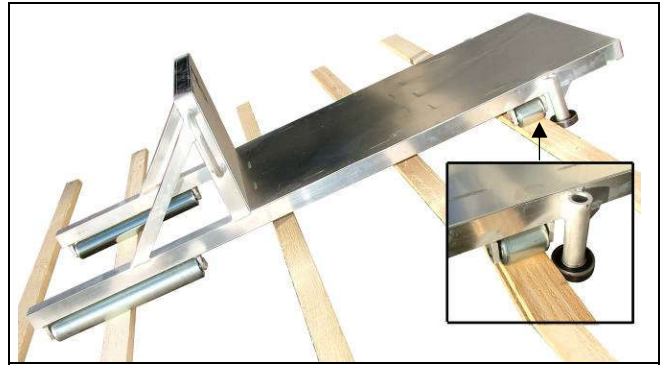

Fig. 16 Roof tile distributor

6.2.5 Power distributor

Construction lifts must be operated by a main cabinet on the building site (see national regulations).

- Drive earth rod (3) into the ground and connect it with the yellow/green PE-conductor on the building site main cabinet.
- Connect mains line of the building site main cabinet (1) with the mains supply on the construction site.
- Test the trigger ability of the fault current circuit breaker by pressing the test button.
- Plug in mains line for the winch (2) on the building site main cabinet.

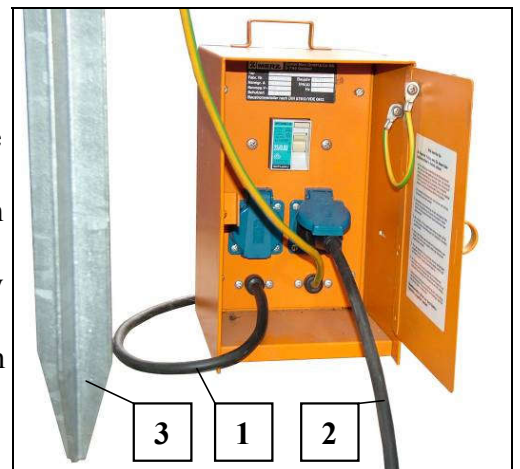

Fig. 17 Power distributor

7 Requirements for the site of installation

7.1 Subsurface

- Level subsurface capable of taking maximum load.
- If this is not available then use the load-distributing supporting bases.

7.2 Electrical connection (on site)

- A building site main cabinet is required on site with an earth leakage circuit breaker with 230 V (110V) 50 Hz and fusing system 16 A slow-to-blow.
- The mains supply line with safety plug is 3 m long. Attach a rubber sheathed cable (at least 3 x 2.5 mm² or 3 x 4mm² at 110V max. 50m) to extend the mains supply line to avoid loss of voltage and therefore any loss in motor performance.

NOTE

With poor power supply, unplug other potential current consumers.

- Connect at 110 V, 50 Hz: 3 x 4,0 mm². - Observe the national provisions of 110V connections.

8 Transport

- On receipt of delivery of the lift, check for any transport damage and for completeness according to your order.
- Immediately inform the carrier and handler of transport damages!
- The lift can be disassembled into individual parts for transport to the construction site.
 - Heaviest part = 56 kg ("LIFT 200 STANDARD" winch)
 - Longest part = 2.20 m

9 Installation



The inclined lift must be constructed in accordance with the assembly and operating manual and under supervision by specialist personnel determined by the employer!

This qualified personnel must be acquainted with the assembly and operating manual, have sufficient experience and be informed about the risks involved in working with the lift.

Assembly personnel

The inclined lift may only be assembled, dismantled and maintained by expert persons (qualified personnel) who can guarantee to handle it appropriately based on their training or knowledge and practical experience and who are aware of the risks. These persons must be specified for assembly, dismantling and maintenance service by the employer.

9.1 General safety notes

- Before each time the machine is assembled, check whether all parts of the lift such as e.g. ladder parts, electrical cables and control system, are in perfect condition. If there is any damage, do not start the lift! – Replace damaged parts immediately.
- Acquaint yourself with the working environment at the place of utilization, e.g. obstacles in the work and traffic area and necessary safeguarding of the construction site from public transport.
- Cordon off danger zone around the lift and mark with warning signs.
- No persons should remain beneath the lift.
- Do not exceed max. rail track length of 19 m up to eaves height! – When lying on the roof, the inclined lift can be extended to any length.
- Observe lift bearing capacity: This depends on the length of the lift, the ladder inclination and whether work is carried out with or without a ladder support. See angle of inclination scale as well as load capacity table on the foot section.
- Conveying persons is forbidden.
- Entering the load suspension device is forbidden.
- Comply with the national accident prevention guidelines from the work protection authorities and all applicable laws and guidelines.
- Wear personal protective gear (e.g. hard hat, safety boots).

9.2 Assemble and set up ladder parts

- It is possible to adjust the length of the lift precisely to up to 25 cm by using the graduated rail lengths (2m, 1m, 0.75m and 0.5m).
- The exact height is aligned by the tilt angle.
- Place the foot section (1) and the following rail parts (3) with the welded on tubes down on the ground.
- Insert the sliding carriage (2) into the foot section (1) (rope breakage safety device (7) must point up).

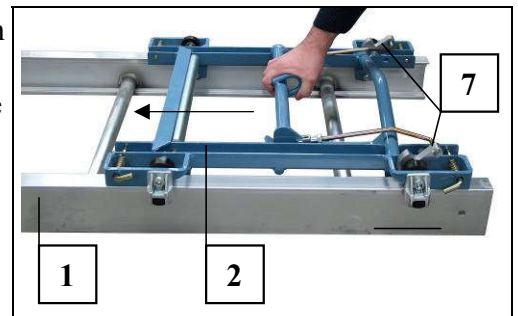

Fig. 18 Insert sliding carriage into foot section

- Put together and screw foot section (1) and rail parts (3) (ring nuts (4) must point outwards).
- Connect ladder parts similarly; see load capacity table on foot section for max. construction length.

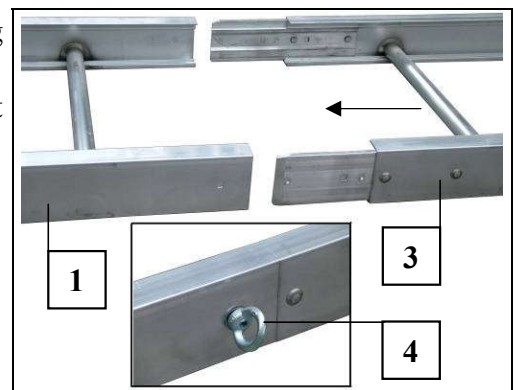

Fig. 19 Put together ladder parts

ATTENTION

Maximum rail track length up to eaves height = 19 metres.

When lying on the roof, the inclined lift can be extended to any length. - For rope capacity see Chp. 5.



The ladder track may only be set up within an inclination angle of 50° - 70°. With an inclination of more than 70°, the ladder track has to be specially anchored.

ATTENTION

Set up the lift in a secure position on a solid and even subsurface. If this is not possible then use the load-distributing supporting bases.

9.2.1 Construction without buckling part

- Place head section (5) at the upper end of the ladder track.
- Rope pulley guard (6) points up.
- Push locking screw through from the inside and screw from the outside with a spring washer and ring nut (4).

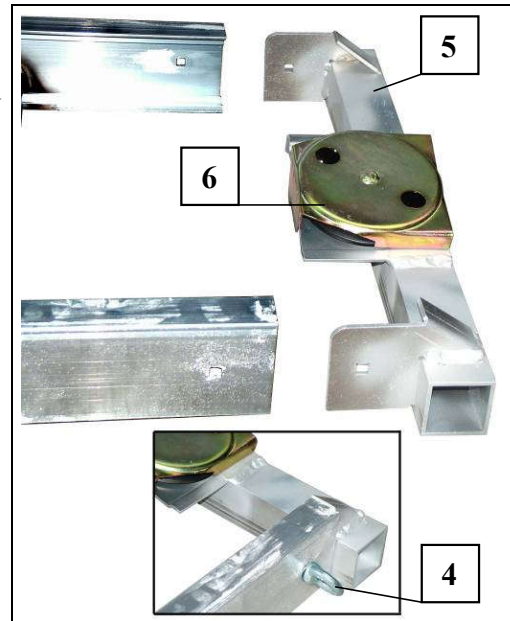

Fig. 20 Assemble head piece

- Set up ladder track. - You might have to place a rope around the head part and pull it up.
- Secure upper area of ladder track, e.g. head part, against slipping (secure to building or lash down tightly).
- Secure the foot section and support to the ground (dowel it, peg it or such like)

9.2.2 Construction with buckling part

- The buckling part (8) is placed on the upper end of the ladder track and screwed in.
- Push locking screw through both elements from the inside and screw from the outside with a spring washer and ring nut (4).

ATTENTION

The buckling part must fit against the eaves. The buckling part can be turned for easier fitting (long side 0.66 m; short side 0.33 m).

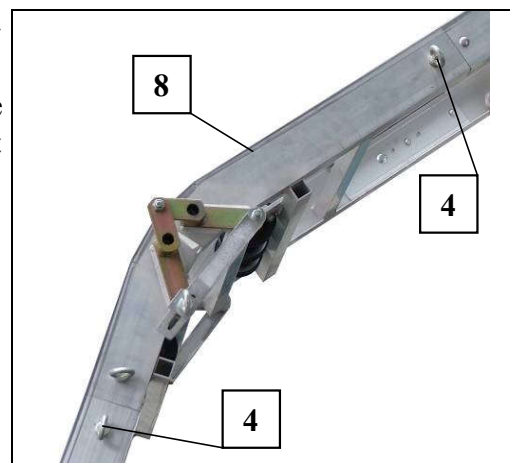

Fig. 21 Assemble buckling part

- Set up ladder track. - You might have to place a rope around the buckling part and pull it up.
- Loosen ring nuts (9) on adjustment clamp (10) and adjust buckling part (8) to the slope of the roof.
- Progressively adjustable from 20°- 45°
- Position requisite ladder parts, or at least a 2m ladder part, on the buckling part (8) and screw in the ring nuts (4).
- Re-tighten ring nuts (9) on the adjustment clamp of the buckling part (8). - Toothing must interlock precisely

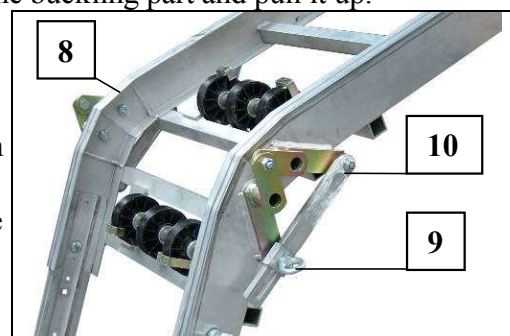

Fig. 22 Adjusting buckling part

The standard buckling part (11) can be used as a simpler alternative to the buckling part described above.

- Assembly is carried out just like with the buckling part described above, but it cannot be turned.
- The standard buckling part (11) is likewise progressively adjustable between 20°- 45°.
- Loosen ring nuts (12), adjust aluminium profile (14) to the slope of the roof. The transfer from the aluminium profiles to the surface of the steel mount (13) must be adjusted so that it is as flush as possible.
- The adjustment of the aluminium profile (14) can be done above and below the steel mount (13).
- Re-tighten ring nuts (12).

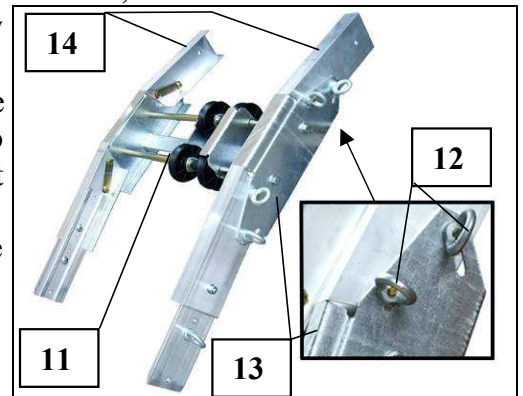

Fig. 23 Standard buckling part

NOTE

Following the buckling part, the inclination angle of the ladder track must be at least 15° to ensure frictionless return of the sliding carriage.

- Position and screw in head section (5) at the end of the ladder part. - Rope sheave points up (see Fig. 20)
- Secure head section to building.
- Secure the foot section and support to the ground (dowel it, peg it or such like)

9.3 Using ladder supports

The GEDA inclined lift can be operating with or without ladder supports. The respective load bearing capacity can be found on the sticker on the base unit from Fig. 24 Fig. 25.

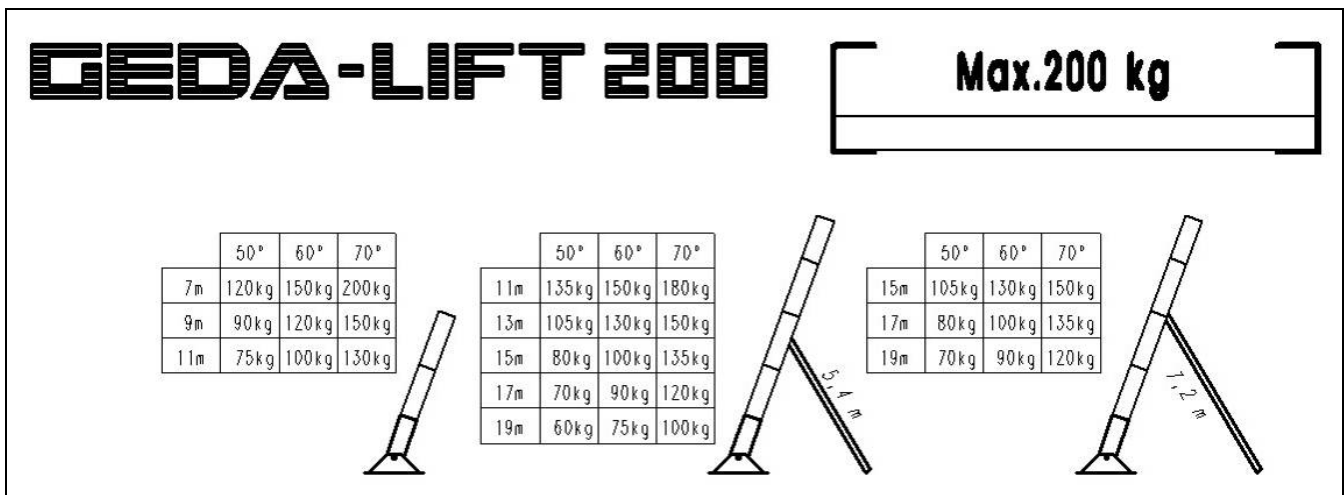

Fig. 24 Load capacity table for ladder parts 150/200 kg

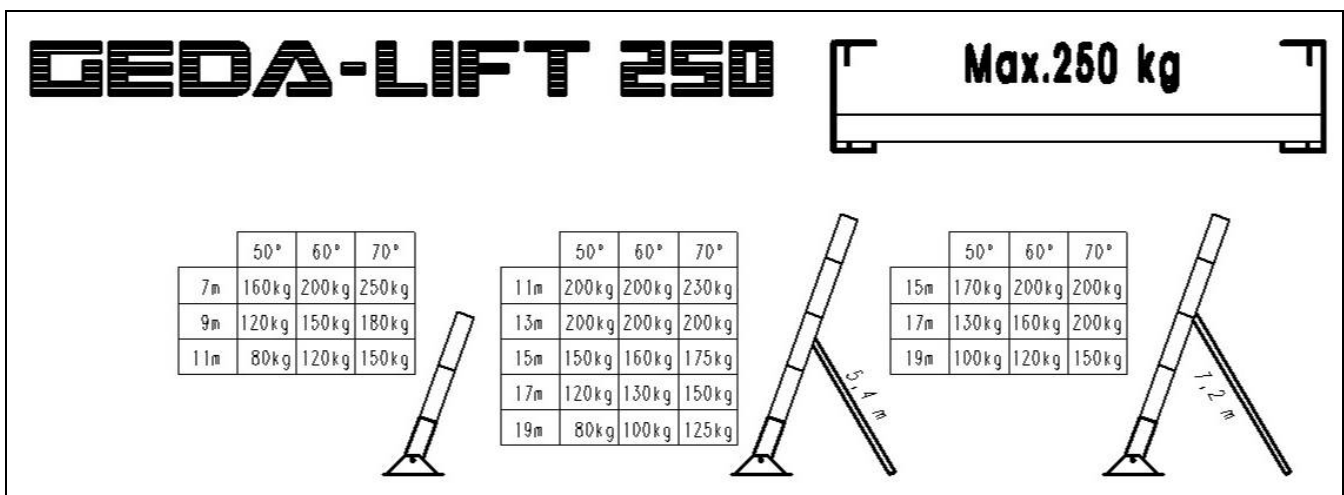

Fig. 25 Load capacity table for ladder parts 200/250 kg

NOTE

The weight information in the load capacity tables only applies with the standard carriage (14.4kg) and universal carriage (31kg). With use of the tilting dump carriage or other load suspension devices, the weights given in the load capacity tables are reduced by the additional weight of these components.



On all lift types, the foot section is constructed uniformly to a max. 250 kg bearing capacity.

The load capacity table states the permissible load bearing capacities depending on the following factors:

- Ladder parts 150/200kg or 200/250kg;
- Total length of ladder track;
- Operation without or with 5.4 m or 7.2 m support;
- Load suspension devices;

- Determine the angle of inclination for the ladder track on the scale on the foot section and read it off the bearing capacity on the load capacity table. – If necessary, use the ladder support with 5.4 m or 7.2 m.



Fig. 26 Scale for the angle of inclination

- Put together the upper part of the ladder support (1) and the lower part of the ladder support (2) with them lying on the ground and secure (bolts with spring cotters (3)).
- The aluminium ladder support can now be extended to 5.7m. If a longer ladder support is required then the extension tube (without illustration) must be used and it can then be extended to 7.2 m.

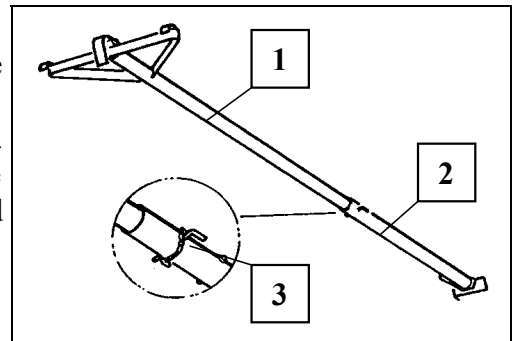

Fig. 27 Aluminium ladder supports

NOTE

The ladder support length should be selected in such a way that the ladder support can be hooked as close to the centre (or a bit below) of the rail track as possible, and the support also stands at approx. 80° to the ground (Fig. 30)

- Hook the aluminium ladder support in the centre of the ladder from above into the ladder rung. - The safety catch clicks in on its own and can be released again by pulling on the cord.

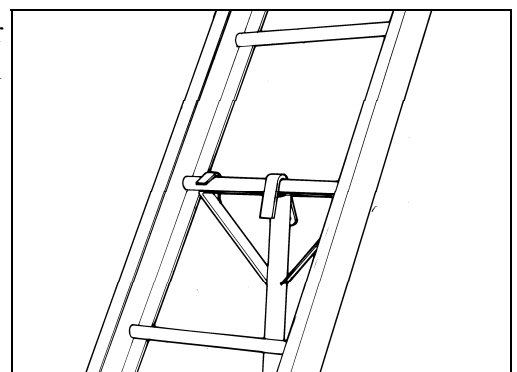

Fig. 28 Aluminium ladder supports

- Remove the pull-out tube by loosening the tension lever (4) and adjust to the desired length.

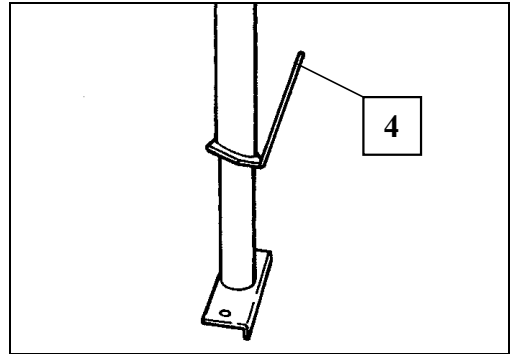

Fig. 29 Tension lever

- Secure the ladder foot section and the support foot section with pegs. Observe the recorded angle.

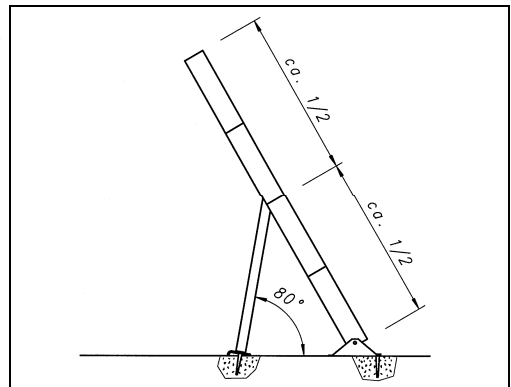

Fig. 30 Adjustment angle of the ladder supports



The ladder track may not be over-tensioned by the ladder support. The natural deflection of the ladder may only be cancelled out by the ladder support by up to a maximum of half. Pay attention to the correct sloping angle of the ladder support.

ATTENTION

The ladder foot section and aluminium ladder support must stand on a stable subsurface and be secured.

9.4 Using rope winch

- Place rope winch (1) from behind on the lowest rung of the foot section (2).
- Pull up both stopping levers (3) with your forefingers and tip the winch up until the bolts click around the rung.



Fig. 31 Using rope winch

For the GEDA LIFT 250 COMFORT and GEDA FIXLIFT 250 winch

- Insert manual control (4) plug (5- or 7-pole) into the winch.
- Insert upper limit switch cable (5) with 3-pole plug into the winch.

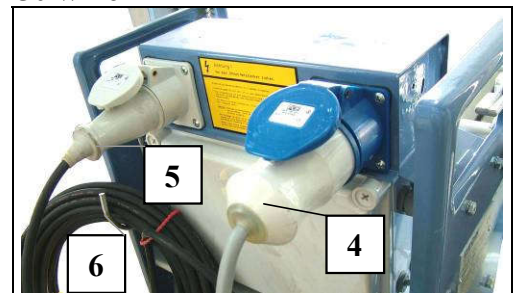

Fig. 32 Plug panel on the winch

- Feed limit switch cable to the head section and assemble limit switch to the desired stop point on the right-hand lift rail.
 - However, it must be at least 120 mm away from the head section.
 - Clamp to the lower leg of the ladder.
 - Limit switch reel must point up.

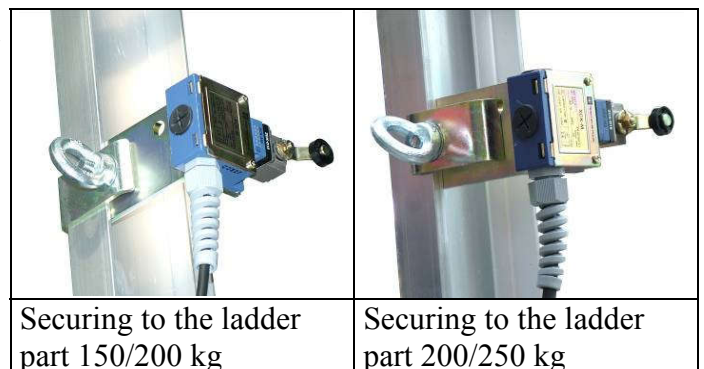

Fig. 33 Assembly upper limit switch

- Carefully roll up the excess cable and hang on the hook (Fig. 32 Pos 6). - Otherwise it presents a hazard from catching on something or from the cable being damaged.
- Connect network cable to the building site main cabinet

9.5 Rope assembly

- Hang rope (1) on the rope winch out of the spring loop (2).
- Press DOWN button on the control cylinder. - Unwind enough rope; keep rope tight so that the slack rope switch (3) remains in its operating position.

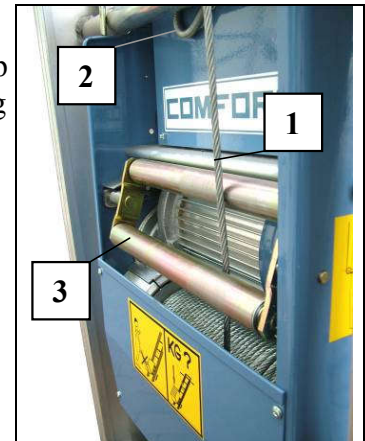

Fig. 34 Unwind rope

- Feed rope on right-hand ladder runner between sliding carriage and rungs.
- Pull out rope pulley guard (4) on head section and turn it a bit.
- Place rope (1) over the rope pulley.

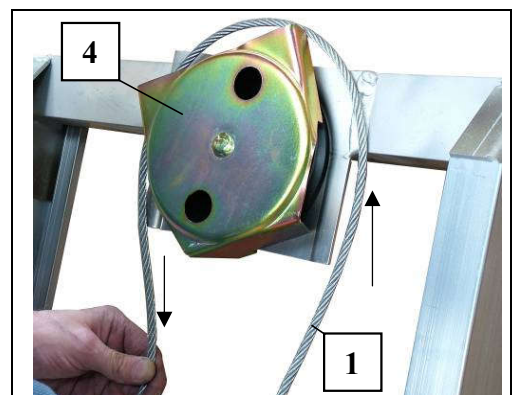

Fig. 35 Feed rope over head section

- Turn back rope pulley guard (4) - see PVC sticker!

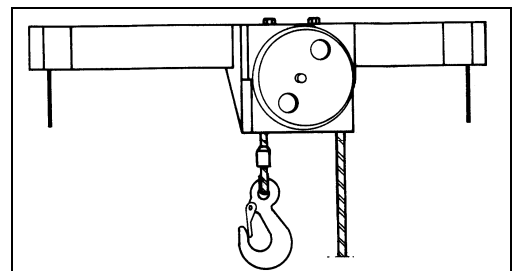

Fig. 36 PVC notice on head piece

NOTE

The rope end with hook must be located in the centre of the ladder.



Fig. 37 Rope guide on buckling part

- Hang rope hook in lug (5) on sliding carriage behind the cross tube.
- Check rope breakage safety device (6) for ease of movement.
- Unwind loose rope cleanly while keeping it tight.
- Assemble platform to sliding carriage (see Chp. 9.6 Assembling load platform).
- Carry out test run without load, if necessary, correct the upper limit switch.



Fig. 38 Hang rope on sliding carriage

9.6 Assembling load platform



It is prohibited to enter the load suspension device or to use it for conveying persons.

The load platforms are usually secured to the 4 spring latches on the sliding carriage.

Exception: Dumping skip with tipping device (see Chp. 9.6.7)

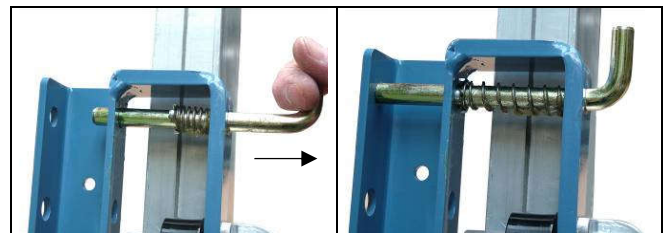

Fig. 39 Spring latch on sliding carriage

9.6.1 Universal platform

Weight = 31kg

NOTE

The foldable side guard is not assembled for packaging reasons.

- Assemble side guard.
 - Loosen and remove hexagon nuts (3) above and below on the reverse of the universal platform (1).
 - With the springs pointing down, place the side guard on the bearing section (2) and fix with hexagon nuts (3).
 - Screw down above and below again to the bearing section (2) with the screws supplied (4).
 - Assemble second side guard in the same way.

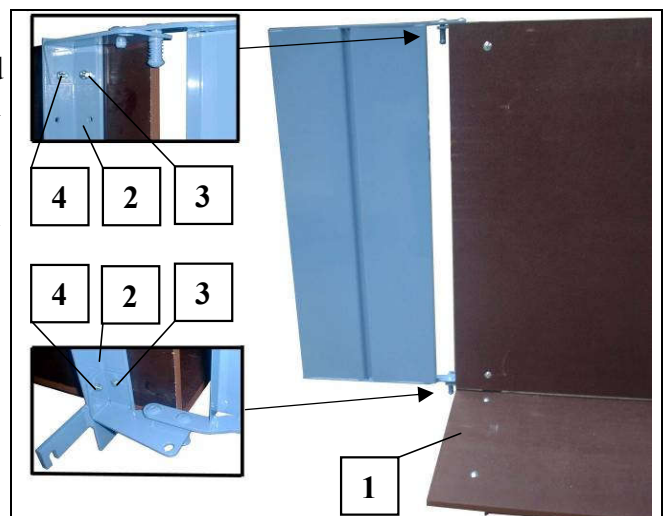

Fig. 40 Putting together the universal platform

The universal platform may be equipped with a front guard (accessories). This front guard (9) must likewise be assembled.

- Remove the outside nuts (11) and split washers from the preassembled screws (M12 x 40).
- Feed the front guard with the screws (10) on the front bore holes of the bearing section (see Fig. 43 Pos. 8) of the universal platform.
- Mount the split washers and nuts (11) on both sides.
- Adjust the inside nuts on both sides so that the front guard remains movable.
- Tighten both outside nuts (11).

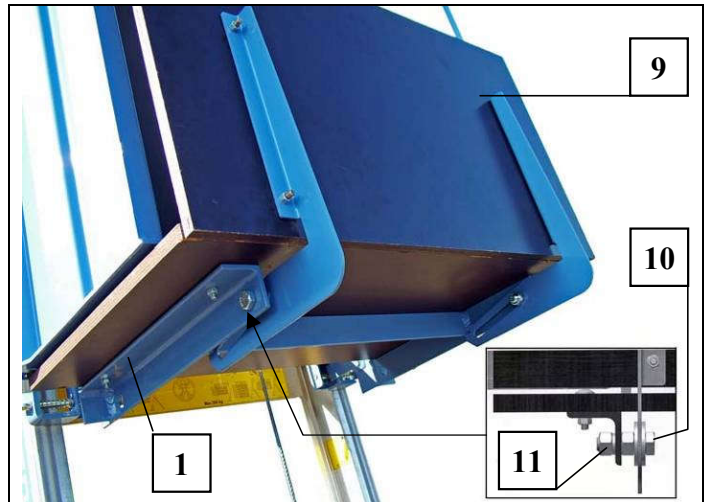

Fig. 41 Front guard for universal platform

Inspection procedures

Lift the front guard (9) somewhat and pull outward until it stops. Now the front guard (9) can be pivoted downward to facilitate loading the universal platform. Finally, pivot front guard (9) upward and slide onto the universal platform until it clicks.

- Hook universal platform (1) onto the lower spring latches (5) on the sliding carriage and secure on both upper spring latches (6).

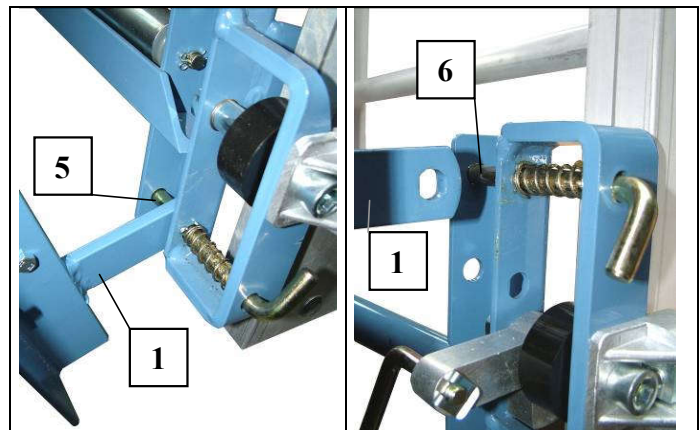

Fig. 42 Assemble universal platform

NOTE

With enclosed side guard (7), the universal platform has an interior width of approx. 67cm. For wider sections, pull the side guard (7) up and fold out.

ATTENTION

The unfolded side guard (7) is used merely as a safeguard and not as a load-bearing surface.

- Secure load with a rope, or similar equipment, in the four bore holes (8) provided on the platform.

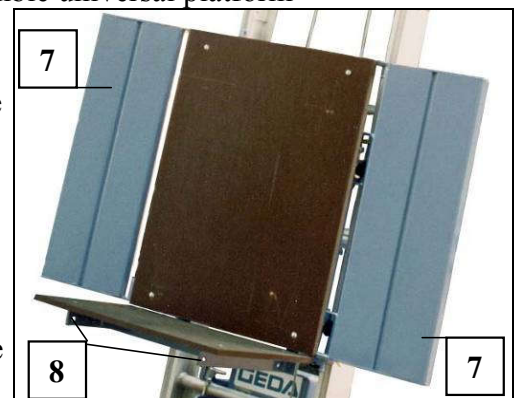

Fig. 43 Universal platform

9.6.2 Bucket hoist (on universal platform)

The bucket hoist can only be used in combination with the universal platform. It is used for conveying max. three buckets even beyond the buckling part.

- Place bucket hoist (2) from above (between the bearing sections) on the universal platform (1).

Weight = 6.5kg



Fig. 44 Bucket hoist

9.6.3 Vario-platform

Weight = 38kg

The horizontally adjustable vario-platform is used for conveying loads.

NOTE

The foldable side guard is not assembled for packaging reasons.

- Mount folding side guards (5) (see Fig. 40) Assemble board (6) from above onto the bearing section with two screws respectively (7).

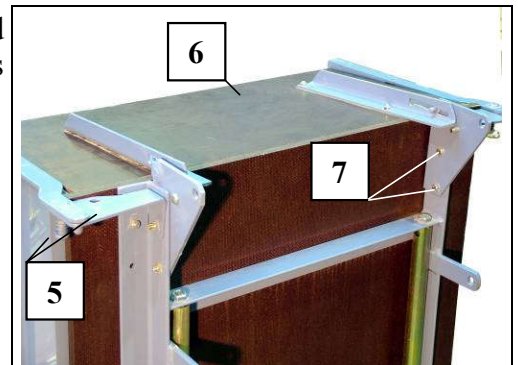

Fig. 45 Assembling vario-platform board

There are two ways to assemble the vario-platform to the sliding carriage.

1. Parallel to the ladder track

- Hook vario-platform (like the universal platform) to the lower spring catches on the sliding carriage and secure on both upper spring catches (see Fig. 42).

2. Horizontal position (Bearing capacity max. 200kg)

- Remove support latch (4).
- Pull telescopic tube (8) out of the locking screw (9) and unfold.
- Secure telescopic tube (8) again.

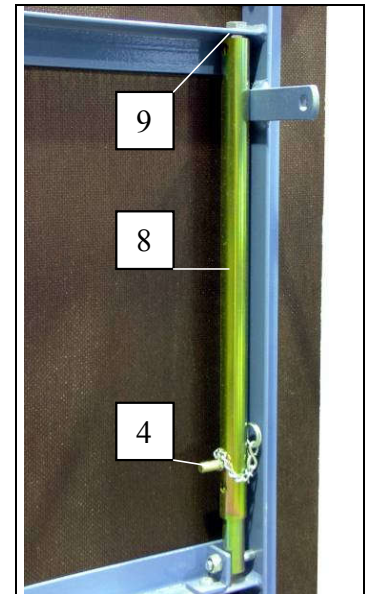

Fig. 46 Vario-platform telescopic support

- Secure vario-platform (1) on the two upper links with the spring latches.
- Fold up vario-platform and secure the telescopic tubes (2) below on the sliding carriage with the spring latches (3).
- Adjust and secure the vario-platform to the support latches (4) horizontally or slightly inclined to the rail track (approx. 5°).

NOTE

The load platform can be adjusted to and secured at the angle of inclination to the rail track (in 5° increments).

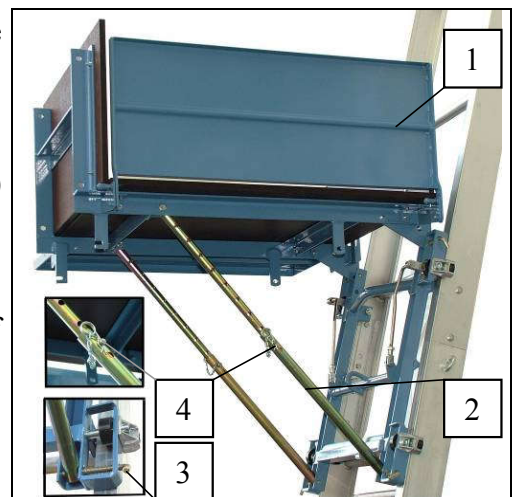

Fig. 47 Vario-platform

- The board wall (6) is unfolded unloading at the ladder end.
- Lift board (6), unfold and push to the back wall of the platform (10).
- With wider parts the side guards (5) can be folded where you pull them up and unfold horizontally.

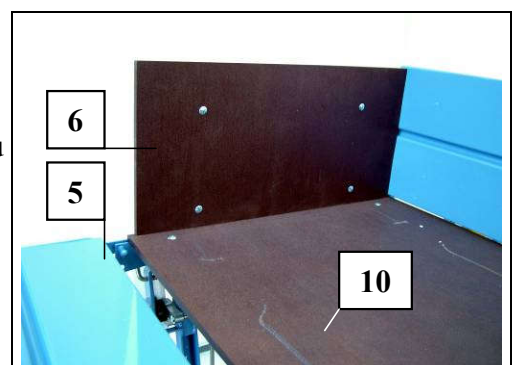

Fig. 48 Unfolding board and side guards

ATTENTION

The unfolded side guard (5) is used merely as a safeguard and not as a load-bearing surface. Thoroughly secure load. - Think about sudden winds. Any load that projects over the load suspension device must be additionally secured!

9.6.4 Large transport platform

Weight = 55kg (The bearing capacity is reduced by 20kg from the weight information of the load capacity table, yet is limited to a max. 200kg)

NOTE

The foldable side guard is not assembled for packaging reasons.

- Assemble boards.
- Open spring latch (3) on the frame (1) of the transport platform and fix by turning it.

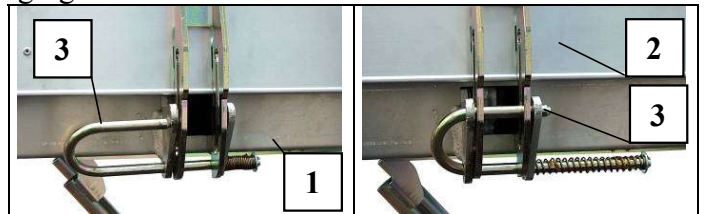

Fig. 49 Assembling boards to the transport platform

- Place board (2) onto the frame (1) and secure with spring latch (3).
- The transport platform is secured with the four spring latches to the sliding carriage.
- Open and lock all four spring latches (5).
- Secure platform on both front stop links (10) (with the telescopic tube down) to both upper spring latches (5) of the sliding carriage.

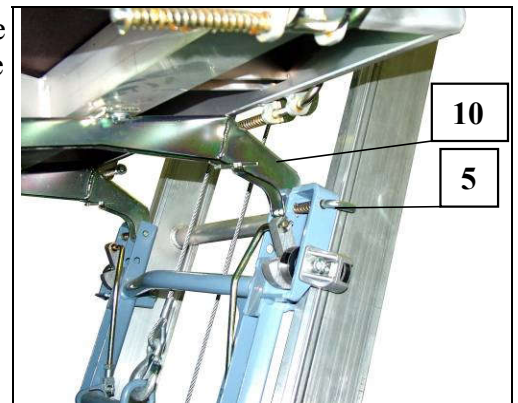

Fig. 50 Assembling large transport platform

- Fold up large transport platform and secure the telescopic tubes (4) below on the sliding carriage with the spring latches (5).
- Adjust and secure the platform horizontally or slightly inclined to the rail track (approx. 5°) to the spring latches on the support (6).
- The transport platform can be adjusted to and secured at the angle of inclination to the rail track (in 5° increments).

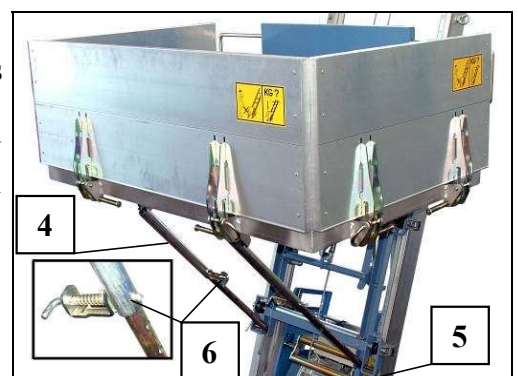

Fig. 51 Transport platform

- If a greater sloping angle of the load platform to the rail track is needed, then the telescopic supports can be screwed onto the front bore holes (7) of the brackets.

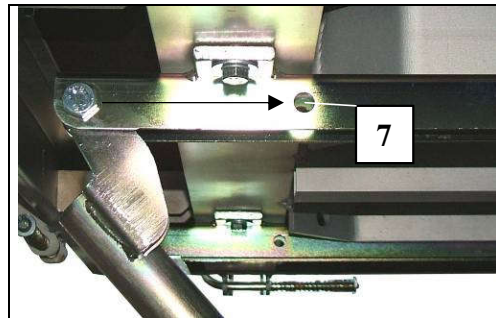

Fig. 52 Secure telescopic supports

- Position the boards horizontally for bulky parts. However, make sure that the conveyed material is **secured** by lashing straps etc.
- Push board (2) up, fold down until it is horizontal and push or drop down in the base frame of the platform until it is hanging down.
- The bearing capacity of the boards is max. 100 kg!

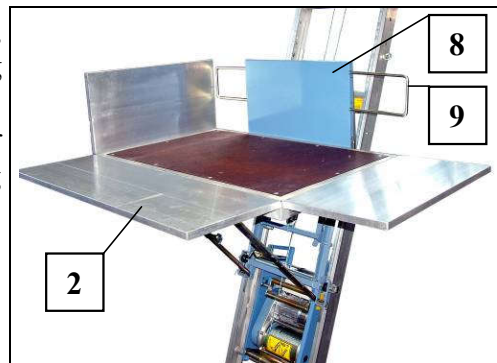

Fig. 53 Adjusting boards



Projecting loads are not allowed!
The bearing capacity of the boards is max. 100 kg!

- The front board (8) can also be unfolded (e.g. for easier loading on the upper ladder track end).
- Push protective clamp (9) in (see Fig. 53).
- Lift board (8) up, unfold and push into the frame of the platform.

9.6.5 Platform

Weight = 40kg

Lifting capacity max. 200kg

Platform for transporting bulky elements (plate width of 0.5 to 1.6 m).

- Secure platform (1) to the four spring latches with the sliding carriage moved partially up.
- Loosen eye bolts (3), then the take-up area (4) of the platform can be adjusted. External width of the platform is adjustable from 0.5 m to 1.10 m. - Expand platform (1) evenly on both sides!
- Secure plates with tension clamp (2) before transporting.

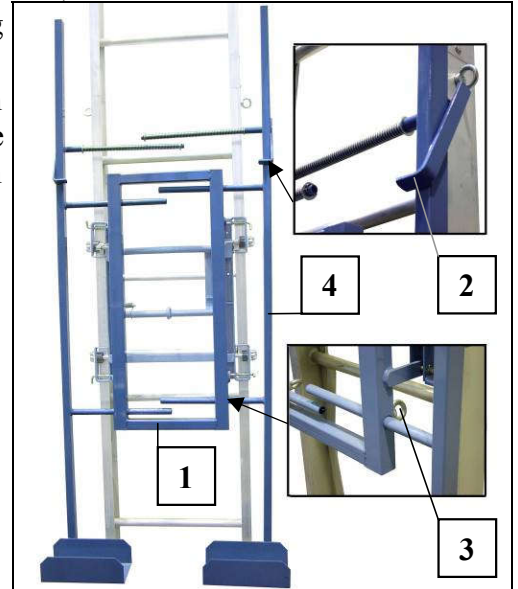

Fig. 54 Platform

Stabilizers for unburdening the ladder track are necessary if the platform is being unloaded in a room.

- Insert the stabilizer (5) after the buckling point into the two tubes of the ladder track and secure with both drop latches.
- Secure telescopic supports (6).

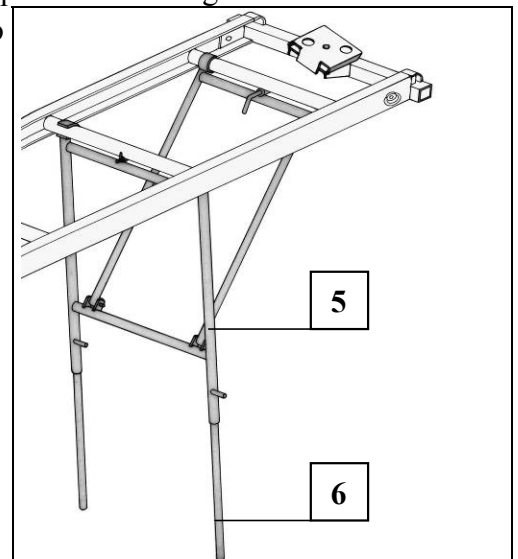

Fig. 55 Stabilizers for ladder track

9.6.6 Brick platform

Weight = 40kg (The bearing capacity is reduced by 9kg from the weight information of the load capacity table, yet is limited to a max. 200kg)

Brick platform with raisable wire mesh guard, hand truck and two palettes for roofing.

- Secure the brick platform (1) on both lower bolts of the sliding carriage. - Clicks in by itself when tipped up.

Loading

- Pull lever (4) and position brick platform (1) vertically.
- Fold up guard (2) (remains open).

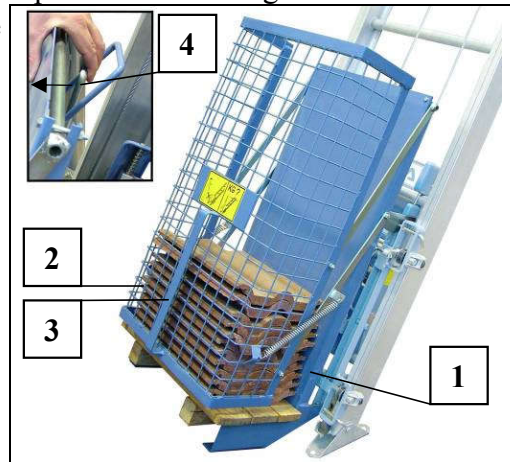

Fig. 56 Brick platform

- Transfer loaded pallet (5) with hand truck (6) on to the brick platform (1).
- Fold up guard (2) with handle (3).
- Tip up brick platform until it audibly clicks into the sliding carriage.

Unloading

Fold up the guard (2) again for unloading. - Guard remains open.

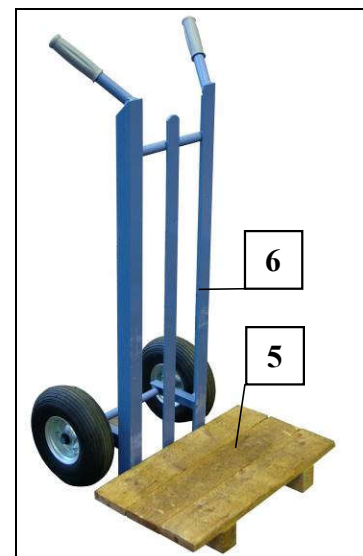

Fig. 57 Hand truck for brick platform

9.6.7 Dumping skip with tipping device (only on standard carriages)

Weight (dumping skip) = 40kg
Lifting capacity max. 150kg

A tipping device, which is mounted to the upper end of the ladder instead of the head piece, automatically tips out the dumping skip.

ATTENTION

Only use the tipping device in connection with the buckling part, as problem-free **emptying of the dumping skip can only be achieved with a ladder inclination of 10° to 30°**.

Prerequisite:

- Window opening at least 80 x 100 cm.
- From upper edge of tipping device to ceiling at least 0.7m.

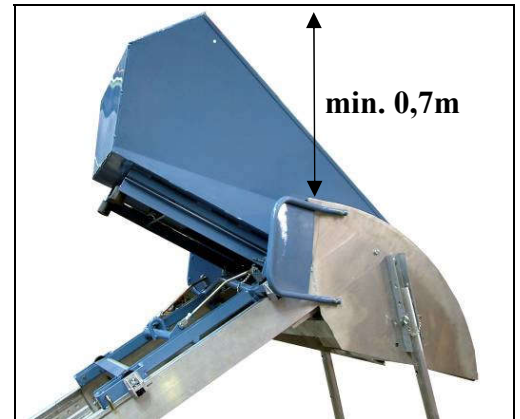

Fig. 58 Dumping skip with tipping device

- Secure dumping skip on both links (1) between the U-shaped rails above on the sliding carriage (2).

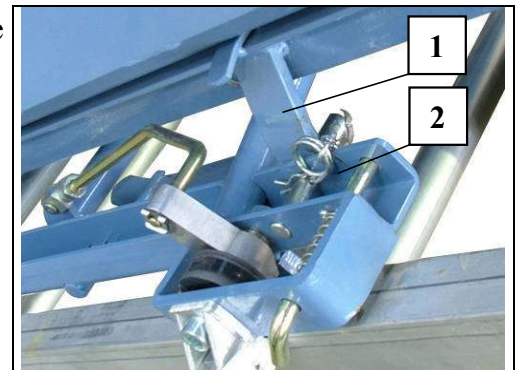

Fig. 59 Assembling dumping skip

- Dismantle head section on upper end, place on tipping device (3) and screw in. - Supporting tubes (4) should be as vertical as possible.

Adjusting the angle of the supporting tubes:

- Remove socket pins and take out support tubes (4).
 - Remove both ring nuts on the inside of the tipping device (3) and take out screws.
 - Position both tube mounts (5) as vertically as possible and screw in again.
 - Push supporting tubes (4) into tube mount (5) again and adjust height. Secure supporting tubes (4).
- Assemble protective clamp
 - Screw in protective clamps (6) to the tipping device (3) on both sides.

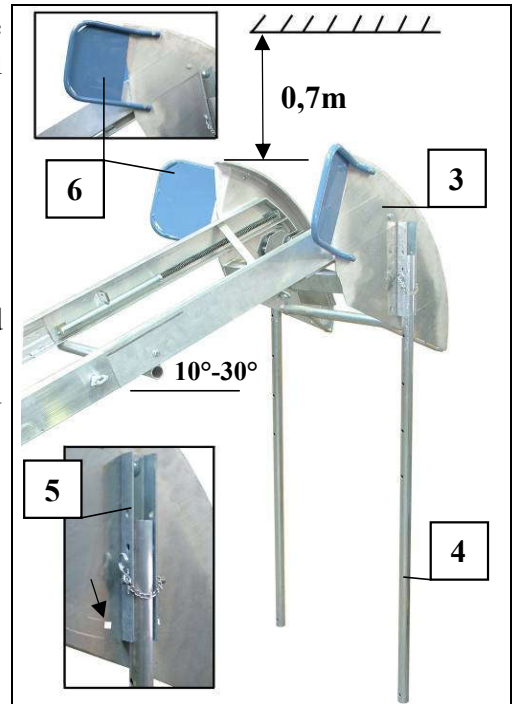

Fig. 60 Tipping device

Insert rope:

- Remove rope pulley (7) from rope pulley casing.
- Form rope loop and push from above through the rope pulley casing.

NOTE

The rope end with hook must be located in the centre of the ladder track.

- Place rope pulley (7) into the loop, draw back the loop with the pulley, lay in casing and secure.

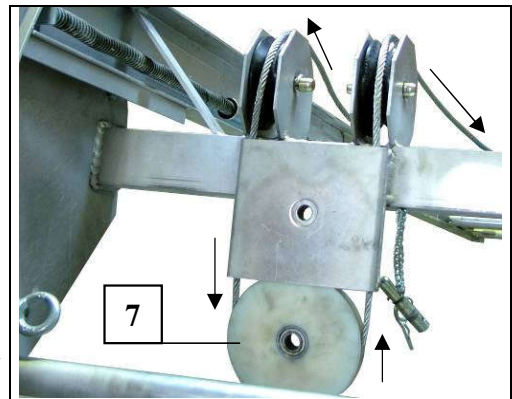

Fig. 61 Rope assembly on tipping device

- Hang rope end with hook in lug on sliding carriage.
- Feed the rope through between the intermittent rope safeguard and rope pulley on the buckling piece and pull tight.
- Set limit switch (pay attention to stop point).
- Carry out test run without load.

Emptying the dumping skip on the ground

- The dumping skip (8) can be unloaded manually from the side, e.g. for transporting construction rubble.
 - Stop dumping skip about 1 m from ground.
 - Pull lever (9) down.
 - Turn dumping skip (8) to the side and empty.
 - Turn dumping skip back. - Clicks into place by itself.

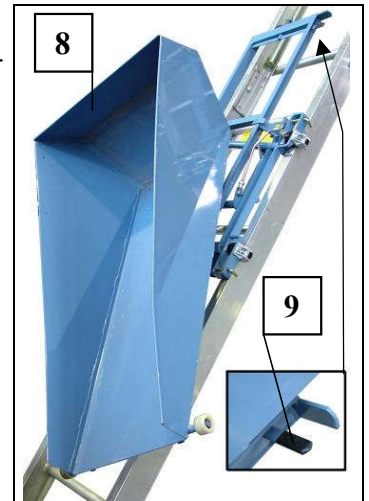

Fig. 62 Emptying dumping skip

9.6.8 Using tilting dump carriage

The tilting dump carriage (1) has a maximum tipping angle of 130°. A special dumping skip belongs to the tilting dump carriage (1) (see chapter 9.6.9).

Weight = 45kg (The bearing capacity is reduced because of the tilting dump carriage by 30kg from the weight information from the load capacity table. Additional reduction see Load suspension devices.)

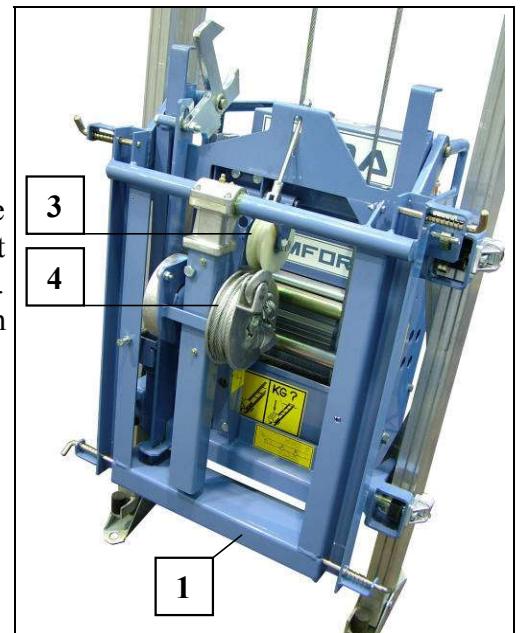

Fig. 63 Tilting dump carriage

- While working with the tilting dump carriage at the head section, assemble two start-up plates (2) (which the hook of the tilting dump carriage grabs on to) with screws M 8 x 85.

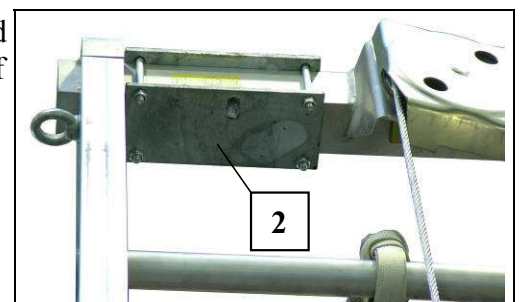

Fig. 64 Start-up plate on head section

- Rope assembly
 - Unwind enough rope (keep rope tight so that the slack rope switch is bypassed). Feed to the head section between sliding carriage and rungs.
 - Turn rope pulley guard, place rope over rope pulley and turn back rope pulley guard.
 - Feed rope down centrally. - The rope end with hook must be located in the centre of the ladder track.
 - Feed rope around the moveable pulley (3) of the rope breakage safety device and place 4 rope windings (approx. 2 m) in the rope grooves on the rope drum (4) and hang the hook to the side.
 - Pull rope tight.

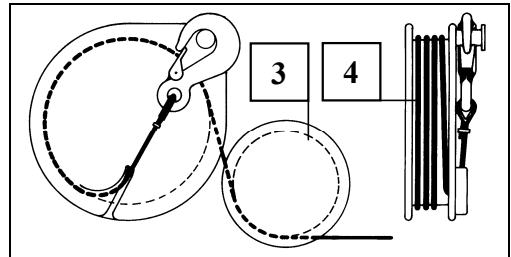

Fig. 65 PVC notice for rope assembly

- Position necessary load suspension device.
- Carry out test run without load, if necessary, correct the limit switch.

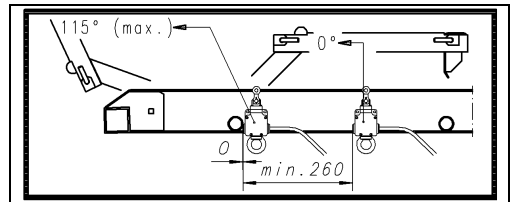

Fig. 66 PVC notice for limit switch

9.6.9 Dumping skip for tilting dump carriage

A special dumping skip that unloads directly over the head section. A buckling part is not necessary for this.

The dumping skip has a capacity of 65 litres with a ladder inclination of approx. 60°.

Dumping skip weight = 31kg

Weight tilting dump carriage = 45kg

(The bearing capacity is reduced by 30kg from the weight information of the load capacity table, yet is limited to a max. 200kg.)

- Secure dumping skip (1) on the four spring latches (2) on the tilting dump carriage.

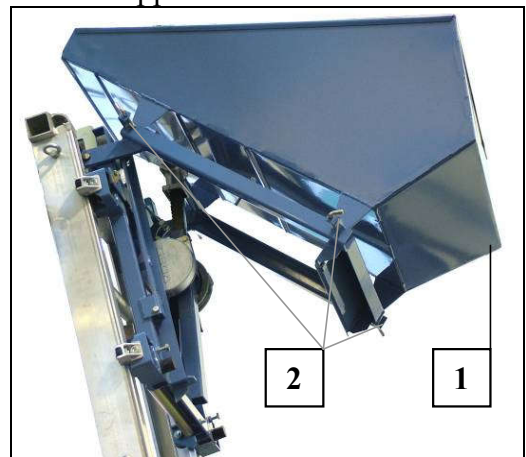

Fig. 67 Dumping skip on tilting dump carriage

9.6.10 Platform with tilting dump carriage

There are great advantages to using the platform (1) (chapter 9.6.5) together with the tilting dump carriage (2) as the transported material can be removed horizontally at the upper unloading point.

Tilting dump carriage weight = 45kg

Platform weight = 40kg

(The bearing capacity is reduced by 40kg from the weight information of the load capacity table, yet is limited to a max. 200kg.)

- Secure platform (1) to the four spring latches with the tilting dump carriage (2) moved partially up.

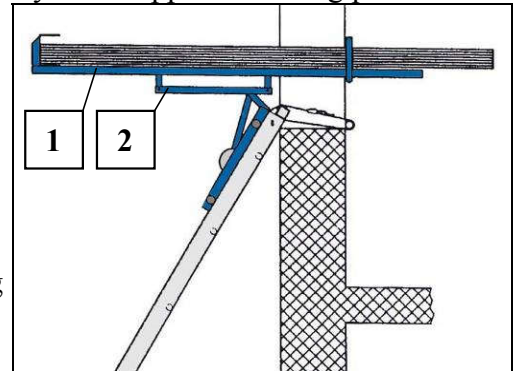

Fig. 68 Platform with tilting dump carriage

9.6.11 Transfer control system

With a transfer control system, the inclined lift can be operated from above or from below so that the load suspension device is always in the operator's field of vision.

If the upper area of the ladder track cannot be seen by the operator, then a transfer control system must be used.

- Hang transfer control system on the winch.
- Insert plug (2) for the transfer control system (1) on the winch socket.
- Insert 5m manual control in the transfer control system.
- Feed transfer control switch with additional control system to buckling part.

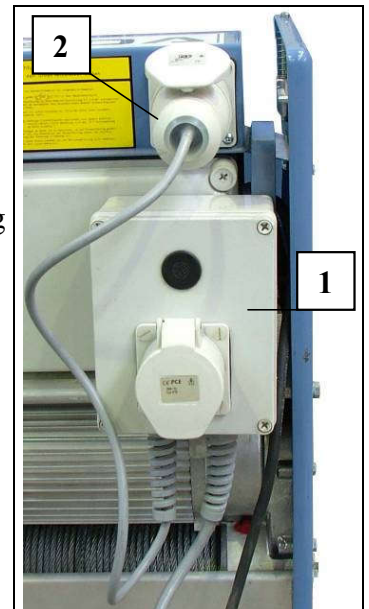

Fig. 69 Transfer control system

- The transfer switch (3) is set in the area of the buckling part. The area of the ladder track that can only be seen from above can only be operated from above with a second manual control. The load suspension device is automatically stopped at the transfer switch (3). At this point, the control is handed over to a 2nd operator. The transfer switch (3) can be clamped at any height.

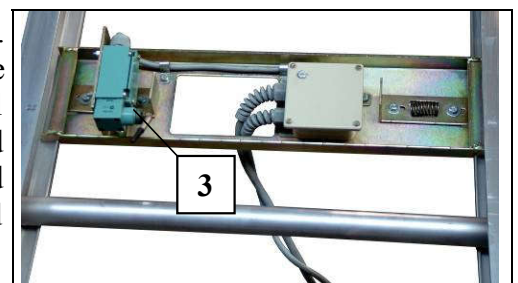

Fig. 70 Transfer switch

ATTENTION

The GEDA LIFT 200 STANDARD can only be used without a transfer control system, for this reason it can only be operated from a position where the operator has a complete overview of the entire length of the track with a permanent 5 m long control.

10 Operation

10.1 Safety notes



The lift may only be operated by qualified personnel determined by the employer. This qualified personnel must be acquainted with the assembly and operating manual, have sufficient experience and be informed about the risks involved in working with the lift.

Conveying persons is forbidden!

- Operating personnel (see Chp. 3)
- Cordon off danger zone around the lift and mark with warning signs.
- The lift is to be operated from outside the danger zone.
- Before starting work at the place of utilization, acquaint yourself with the working environment, e.g. obstacles in the work and traffic area and necessary safeguarding of the construction site from public transport.
- The operating personnel must always be able to see the load suspension device clearly and must monitor the run of the load platform or the load suspension device.
- Secure the lift thoroughly against unauthorized access! - Store manual control securely at the end of work/during breaks.
- If the loaded load suspension device stops during operation due to a malfunction, then the operating personnel must recover the load. - Never leave a loaded load suspension device unattended!
- The load must be evenly distributed over the load suspension device.
- Do not stand or work beneath the load!
- Check at least once a day for externally recognizable damages and defects. Immediately report any changes or malfunctions determined to the company management or his/her authorized representative. If necessary, shutdown and secure the lift immediately.
- Observe national accident prevention guidelines and/or workplace guidelines.
- Wear personal protective gear (e.g. hard hat, safety boots).
- Do not transport bulky goods that project over the side of the load platform.
- Position the load securely; material that tends to slip or is higher than the platform or could fall must be secured. (Think about sudden winds)
- Check ease of movement on rope breakage safety device
- Lift may only be operated in inclined position.
- Also observe the safety notes in Chapter 4.
- Do not enter the load suspension device!

10.2 Impermissible mode of operation

- Exceeding the bearing capacity (see also load capacity table).
- Exceeding a maximum ladder length of 19 m.
- One-sided loading of the load suspension device.
- The load platform or load suspension device must not be up at the end of work.
- Projecting loads are not allowed!
- The lift operation must cease with:
 - Wind speeds of over 45 km/h (= wind force 5-6; stronger winds).
 - Temperatures below -20°C .
 - Damage or other faults.
 - missing reoccurring check (see Ch. 4.3.1).

10.3 Safety inspection

Before start of work

Carry out a test run with **empty** load suspension device and check whether the sliding carriage runs freely over the entire length.

The actuator must be stopped immediately

- An EMERGENCY STOP button is pressed
- The rope is not tensioned (slack rope switch)
- The sliding carriage has reached the end of the ladder
- The direction button for UP or DOWN is released.

10.4 Operating the lift

NOTE

The rope winches for the GEDA LIFT 200 STANDARD and GEDA LIFT 250 COMFORT have **a speed level** of max. 30m/min. (22m/min. on the GEDA LIFT 200 STANDARD)

The GEDA FIXLIFT 250 winch has two speed levels. They can start the lift movement jolt-free with the low speed (max. 19m/min) and then shift up to the second level (max. 38m/min).

It is also possible to stop more cautiously using the first speed level. The control switch has two pressure points.

10.4.1 Operating the GEDA LIFT 200 STANDARD and GEDA LIFT 250 COMFORT

Control is only possible in tipping mode

- Load up
 - Press UP button (2).
- Load down
 - Press DOWN button (3).
- Switching off or stopping:
 - Release UP button (2) or DOWN button (3).
 - In an emergency by operating the EMERGENCY STOP button (1).

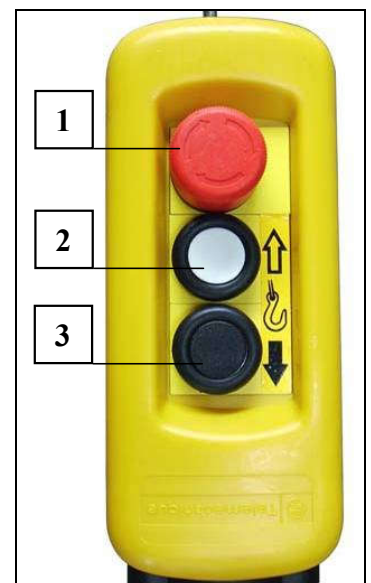

Fig. 71 One-stage manual control

10.4.2 Operating the GEDA FIXLIFT 250

Control is only possible in tipping mode.

- Load up
 - Press UP button (2)
 1. Pressure point approx. 19m/min
 2. Pressure point approx. 38m/min
- Load down
 - Press DOWN button (3).
 1. Pressure point approx. 19m/min
 2. Pressure point approx. 38m/min
- Switching off or stopping:
 - Release UP button (2) or DOWN button (3).
 - In an emergency by operating the EMERGENCY STOP button (1).

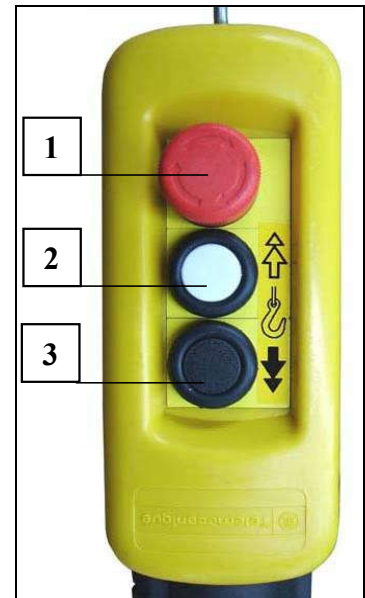

Fig. 72 Two-stage manual controls

10.5 Work interruption/end of work

- Move load suspension device down to lower position with the DOWN button and unload.
- Hang up manual control (if possible) and keep safe.
- Remove mains plug.

10.6 Shutting down in an emergency

- In situations that present a risk for the operating personnel or the lift, shutdown the lift by pressing the EMERGENCY STOP button.
- There is an EMERGENCY STOP button located at each control point.

NOTE

EMERGENCY STOP palm button switches are equipped with a stopping mechanism and remain operated until they are un-locked again manually (turn red button to the right and pull it back).

11 Dismantling (disassembly)



The lift must be dismantled in accordance with the assembly and operating manual and under supervision by specialist personnel determined by the employer!

This qualified personnel must be acquainted with the assembly and operating manual, have sufficient experience and be informed about the risks involved in working with the lift.

The same regulations and safety notes as described in Chp. 9 apply for dismantling.

Also make sure disassembly is carried out generally in reverse order to assembly:

- Cordon off danger zone and attach warning notices.
- Disassembly is carried out in reverse order to assembly.

12 Malfunctions-Cause-Remedy



Faults may only be remedied by qualified personnel!
Before each troubleshooting session, move the load platform (load suspension device) down if possible, and unload or secure the load!
The rope breakage safety device on the sliding carriage is not a locking device.

Remove mains plug before working on the electrical system of the lift. Discontinue operation immediately if faults occur that endanger operational safety!

Check the following if there are faults:

- Mains supply plugged in?
- Fuses in the building site main cabinet? (16 A, slow-blowing)
- Correct extension cable? Wire cross section at least 3x2.5 mm²
- Are the EMERGENCY STOP buttons unlocked?
- Load suspension device overloaded?
- Are the operating elements for the up + down limit switches functioning properly?
- Miniature fuse in switchbox on sliding carriage (63mA slow-to-blow and 250mA).

Motor is not giving full output:

- Fall in voltage of more than 10% of the nominal voltage.
- Select supply cable with higher wire cross section.
- Reduce load.
- If the motor is overheated, the integrated thermal switch turns off the drive motor and the control.
 - Work can continue after a certain cool-off period.

ATTENTION

- Refrain from overheating (overloading) repeatedly. - Otherwise the service life of the motor/brakes will be shortened.

12.1 Possible faults during operation

12.1.1 Electricity failure or motor defect

(Only for the GEDA LIFT 250 COMFORT and GEDA FIXLIFT 250)

In this case, the load platform must be lowered to the ground by releasing the motor brake.

- Feed an average sized screwdriver between the end plate of the motor and the anchor plate of the brake from both sides of the actuator in the bore holes provided (1), and release the motor brake by pushing in a carefully controlled way (into the gear) on the screwdriver (2).
 – load platform glides down.

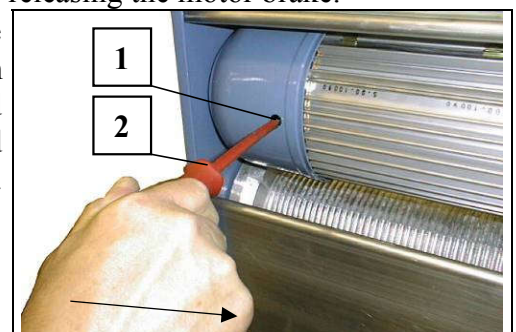

Fig. 73 Releasing the brake

ATTENTION

If the brake is released too much then the load platform goes into overspeed (the motor gets hot)! Have breaks for greater heights. – Brake must not get overheated!

- On reaching the foot section, make sure that the load platform does not hit the ground. Loosen screwdriver (2) in good time.

12.1.2 Load platform is run too high

The load platform runs too high if the upper limit switch has failed (or was not assembled).

- Press down button.
- Stop lift and secure. – Get it checked immediately by qualified electricians!

13 Maintenance



Maintenance work may only be carried out by qualified personnel. Make sure that lubricants and spare parts are disposed of in an environmentally friendly way.

ATTENTION

Before cleaning and maintenance work, first convey the load suspension device down and remove mains plug.

13.1 Check before each use

- Check rope breakage safety device on sliding carriage for ease of movement. Exchange damaged parts.
- Check rope for wear.
- Function of the EMERGENCY STOP button.
If the EMERGENCY STOP button has been pushed, then no upwards or downwards movement by the load platform should be possible!
- Carry out a test run with an empty load platform and check if
 - The entire run of the load platform is free.
 - Are the upper/lower limit switches functioning?

13.2 Weekly inspection/maintenance

- Clean dirt off lift.
- Keep work area around lift clear and clean.
- Check rope for wear (e.g. breakages in the cable braid, squashed points) or for corrosion; if necessary replace the rope. (Order replacement rope at GEDA: Rope 6mm ø DIN 3060 SE 1770, minimum breakage strength 19.7 kN).

13.3 Monthly inspection/maintenance

- Lubricate the gear wheel for the rope winch drum on the lubricating nipple.
- Check the slack rope switch for ease of movement; if necessary oil it.

13.4 Quarterly inspection/maintenance

- Are the notices present and easily legible?
(Bearing capacity, load capacity table, angle of inclination scale, conveyance of persons forbidden).

13.5 Every 3000 operating hours

- Change the grease on the gear of the gear motor.
- Grease quantity = approx. 160g for the "GEDA LIFT 250 COMFORT" and "GEDA FIXLIFT 250" winch
- Grease quantity = approx. 1600g for the winch on "GEDA LIFT 200 STANDARD"
- Recommendation: DIVINOL, ARAL-Lub FD 00, BP-Energrease HTO, ESSO-Fibrax 370

14 Maintenance



Maintenance work may only be carried out by trained and qualified persons because they need special expert knowledge and special abilities. Neither is communicated in this operating manual.

When ordering spare parts please state the following:

- Type
- Year of construction
- Serial No.
- Operating voltage
- Desired piece number

The type plate is located on the base unit of the machine.

NOTE

Spare parts must correspond to the technical requirements of the manufacturer! Only use original spare parts from GEDA.

Place an order with our customer service for servicing or maintenance work:

Sales and customer services addresses:

GEDA®

ORIGINAL

Mertinger Straße 60

D-86663 Asbach-Bäumenheim

Phone + 49(0)9 06 / 98 09-0

Fax + 49(0)9 06 / 98 09-50

Email: info@geda.de

WWW: <http://www.geda.de>

15 Disposing of lift

Professionally dismantle the lift at the end of its service life and dispose of according to national provisions.

- Observe the following when disposing of lift components:
 - Discharge oil/grease and dispose of in an environmentally friendly way
 - Recycle metal parts
 - Recycle plastic parts
 - Take electrical components to hazardous waste recycling.

Recommendation: Get in touch with the manufacturer or authorise a specialist company with the prescribed disposal.

16 Warranty

Please find the warranty conditions in the general business conditions (see invoice or delivery note). Not included in the warranty are damages or defects that occur as a result of non-prescribed electrical connection, improper handling, non-compliance with the assembly and operating instructions. Electrical cables and parts that are subject to normal wear and tear are also excluded. We reserve the right to determine how and through whom the defects are to be remedied.